

# Water Quality Monitor

Model Q46CT Toroidal Conductivity Monitor





---

## CONTENTS

Introduction . . . . .	5
General . . . . .	5
Features . . . . .	6
Q46CT System Specifications . . . . .	7
Q25CT Conductivity Sensors . . . . .	8
Q46CT Performance Specifications . . . . .	8
Analyzer Mounting . . . . .	9
General . . . . .	9
Wall or Pipe Mount . . . . .	10
Panel Mount Monitor . . . . .	12
Sensor Mounting . . . . .	13
General . . . . .	13
Tee Mounting . . . . .	14
Submersion Mounting . . . . .	15
In-Line Installation . . . . .	16
Electrical Installation . . . . .	18
General . . . . .	18
Power Connection . . . . .	19
Relay Connection . . . . .	20
Optional Output or Relay Connections . . . . .	21
Sensor Wiring . . . . .	22
Direct Sensor Connection . . . . .	24
Junction Box Connection . . . . .	25

- Configuration . . . . . 26
  - User Interface . . . . . 26
    - Keys . . . . . 26
    - Display. . . . . 27
  - Software . . . . . 28
    - Software Navigation . . . . . 28
    - Measure Menu [MEASURE] . . . . . 30
    - Calibration Menu [CAL] . . . . . 31
    - Configuration Menu [CONFIG]. . . . . 31
    - Control Menu . . . . . 34
    - Diagnostics Menu [DIAG] . . . . . 37
- Calibration . . . . . 40
  - Overview and Methods. . . . . 40
    - 1-Point Calibration Explained . . . . . 40
    - Zero Cal Explained . . . . . 40
  - Performing Sensor Zero Calibration . . . . . 40
  - Performing a 1-Point Calibration . . . . . 40
  - Temperature Calibration . . . . . 42
- PID Controller Details . . . . . 43
  - PID Description . . . . . 43
  - PID Algorithm. . . . . 43
    - PID Equation . . . . . 43
  - Classical PID Tuning . . . . . 44
  - Manual PID Override Control . . . . . 45
  - Common PID Pitfalls. . . . . 45
- System Maintenance . . . . . 46
  - System Checks . . . . . 46
  - Instrument Checks. . . . . 46
  - Sensor Tests . . . . . 47
  - Display Messages . . . . . 48
- Spare Parts . . . . . 50

# INTRODUCTION

## General

The Model Q46CT Conductivity monitor/analyzer provides a versatile system for monitoring and control of conductivity over a range of 1  $\mu\text{S}/\text{cm}$ ...2.000 Siemens/cm. The display may be programmed for ranges of 0...2000  $\mu\text{S}$ , 0...2.000 mS, 0...20.00 mS, 0...200 mS, 0...2000 mS or 0...2.000 S. A lower line display indicates the equivalent TDS value in mg/L, using a user programmable conversion factor. Q46CT monitors use a toroidal conductivity sensor that measures conductivity inductively. This type of sensor is particularly well suited to measurements in solutions that contain materials that would foul a normal conductivity sensor. It is very good for high conductivity measurements, but should not be used if normal conductivity is below 100  $\mu\text{S}$ .

For special applications, the Q46CT has a few common pre-programmed tables that allow the user to monitor "percent concentration". Selectable tables include NaCl (0...20%), HCl (0...18%), NaOH (0...15%) and KOH (0...15%). If data is available, you can enter your own table data into the Q46CT to provide a customized concentration display for other chemicals in solution.

Monitors are available in two electronic versions: a universal AC powered monitor for operation from 90...260V AC and a 12...24V DC unit. Both versions provide two 4...20 mA analog outputs and 3 SPDT relays. One analog output may be configured for PID control and one of the relays may be configured to provide a remote trouble indication.

The Q46CT is available with a few options to expand the capabilities of the monitor. Users may select either a third analog 4...20 mA output or an expansion card that provides three additional low voltage SPST relays. The expansion relays are not isolated from each other.

This monitor also provides digital communication capability. Users may order Q46 systems with either Profibus DP, Modbus RTU, Modbus/TCP-IP or Ethernet/IP communications boards factory installed.

### **WARNING**

**NOT FOLLOWING OPERATING INSTRUCTIONS MAY IMPAIR SAFETY.**

## Features

- Power options for either AC or low voltage DC operation.
- High accuracy, high sensitivity system, measures from 1...2,000,000  $\mu$ S through 7 internal automatic ranges. User display ranges include 2000  $\mu$ S, 2.000 mS, 20.00 mS, 200.0 mS, 2000 mS or 2.000 S.
- *Output Hold*, *Output Simulate*, *Output Alarm* and *Output Delay* functions. All forced changes in output condition include bumpless transfer to provide gradual return to online signal levels and to avoid system control shocks on both analog outputs.
- Selectable PID controller on main analog output. PID includes manual operation feature, and diagnostic “stuck-controller” timer feature for relay notification of control problems.
- Digital communication option for Profibus-DP, Modbus-RTU. Modbus/TCP-IP and Ethernet/IP. Refer to the specific communications manual for specifications.
- Configurable for TDS display and signal output on one analog output.
- Two analog outputs track conductivity and temperature, conductivity and conductivity or conductivity and TDS. Both analog outputs can be individually programmed to fail to specific values.
- Large, high contrast, custom LCD display with LED back light provides excellent readability in any light conditions. The second line of display uses 5  $\times$  7 dot matrix characters for clear message display.
- Toroidal conductivity sensor. Sensing electrodes are molded in a noryl body and completely isolated from the measured solution. Conductivity measurements can be made in almost any aqueous solution without being affected by high solids, oils and other materials that foul contacting sensors.
- Quick and easy 1-point calibration method and sensor zero-cal. To provide high accuracy, all calibration methods include stability monitors that check temperature and main parameter stability before accepting data.
- High accuracy Pt1000 temperature input. Temperature element can be user calibrated.
- Security lock feature to prevent unauthorized tampering with transmitter settings. All settings can be viewed while locked, but they cannot be changed.



Equipment bearing this marking may not be discarded by traditional methods in the European community after August 12, 2005, per EU Directive 2002/96/EC. End users must return old equipment to the manufacturer for proper disposal.

## Q46CT System Specifications

<b>Displayed Parameters</b>	Main input, 0 $\mu$ S...2 S (2,000,000 $\mu$ S) Sensor temperature, -10.0...210.0° C (23...410° F) Loop current, 4.00...20.00 mA Sensor slope Model number and software version PID Controller Status Timer Status
<b>Main Parameter Ranges</b>	Automatic or Manual selection of display range 0...2000 $\mu$ S 0.0...2.000 mS 0.00...20.00 mS 0.0...200.0 mS 0...2000 mS 0.000...2.000 S
<b>Display</b>	0.75 in. (19.05 mm) high 4-digit main display with sign 12-digit secondary display, 0.30 in. (7.62 mm) 5 $\times$ 7 dot matrix. Integral LED back-light for visibility in the dark.
<b>Power</b>	90...260V AC, 50/60 Hz, 10 VA max. 12...24V DC, 500 mA max.
<b>Enclosure</b>	NEMA 4X, polycarbonate, stainless steel hardware, weatherproof and corrosion resistant.
<b>Mounting Options</b>	Wall or pipe mount bracket standard. Bracket suitable for either 1.50 in. or 2 in. I.D. U-bolts for pipe mounting. Panel mount adapter optional.
<b>Conduit Openings</b>	Five 1/2 in. NPT openings. Adapter can be removed to provide a 1 in. NPT opening in the bottom of the enclosure. Gland seals provided but not installed.
<b>Relays, Electromechanical</b>	Three SPDT, 6 amp @ 250V AC, 5 amp @ 24V DC contacts Software selection for setpoint, phase, delay, deadband, hi-lo alarm and failsafe A-B indicators on main LCD, and C indicator on lower display
<b>Analog Outputs</b>	Two 4...20 mA outputs. Output 1 programmable for pH or PID. Output 2 programmable for pH or temperature. Max load 500 Ohms for each output. Outputs ground isolated and isolated from each other. An additional 3rd analog option is available.
<b>Keypad</b>	4-key membrane type with tactile feedback, polycarbonate with UV coating
<b>Weight</b>	2 lb (0.9 kg)
<b>Ambient Temperature</b>	Analyzer Service, -20...60° C (-4...140° F) Storage, -30...70° C (-22...158° F)
<b>Ambient Humidity</b>	0...95%, indoor/outdoor use, non-condensing
<b>Altitude</b>	Up to 2000 m (6562 ft)
<b>Electrical Certification</b>	Ordinary location, cCSAus (CSA and UL standards - both approved by CSA), pollution degree 2, installation category 2
<b>EMI/RFI Influence</b>	Designed to EN 61326-1
<b>Output Isolation</b>	600V galvanic isolation

## Q25CT Conductivity Sensors

<b>Sensor</b>	Toroidal sensor with encapsulated temperature element
<b>Measuring Range</b>	0.000...2.000 S/cm
<b>Temperature Element</b>	Pt1000 RTD
<b>Wetted Materials</b>	Noryl
<b>Optional Flow Tee</b>	Special 2 in. CPVC tee with alignment slot
<b>Sensor Cable</b>	20 ft (6 m) standard
<b>Pressure Range</b>	0... 150 PSIG
<b>Temperature Range</b>	0... 105° C (302° F)
<b>Maximum Flow Rate</b>	10 ft (3 m) per second
<b>Max. Sensor-Analyzer Distance</b>	200 ft (60 m)

## Q46CT Performance Specifications

<b>Accuracy</b>	0.5% of user range, or better ( $\pm 2 \mu\text{S}$ )
<b>Repeatability</b>	0.2% of user range, or better ( $\pm 2 \mu\text{S}$ )
<b>Sensitivity</b>	0.05% of user ranges ( $\pm 2 \mu\text{S}$ )
<b>Stability</b>	0.2% of user range per 24 hours, non-cumulative
<b>Warm-Up Time</b>	3 seconds to rated performance (electronics only)
<b>Supply Voltage Effects</b>	$\pm 0.05\%$ of user range
<b>Instrument Response Time</b>	6 seconds to 90% of step input at lowest setting
<b>Temperature Drift</b>	Span or zero, 0.04% of span/ $^{\circ}\text{C}$

# ANALYZER MOUNTING

## General

All Q46 Series instruments offer maximum mounting flexibility. A bracket is included with each unit that allows mounting to walls or pipes. In all cases, choose a location that is readily accessible for calibrations. Also consider that it may be necessary to use a location where solutions can be used during the calibration process. To take full advantage of the high contrast display, mount the instrument in a location where the display can be viewed from various angles and long distances.

Locate the instrument in close proximity to the point of sensor installation - this allows easy access during calibration. The standard cable length of the conductivity sensor is 20 ft. For sensor cables longer than 20 ft, use the optional junction box (07-0100) and sensor interconnect cable (31-0057).

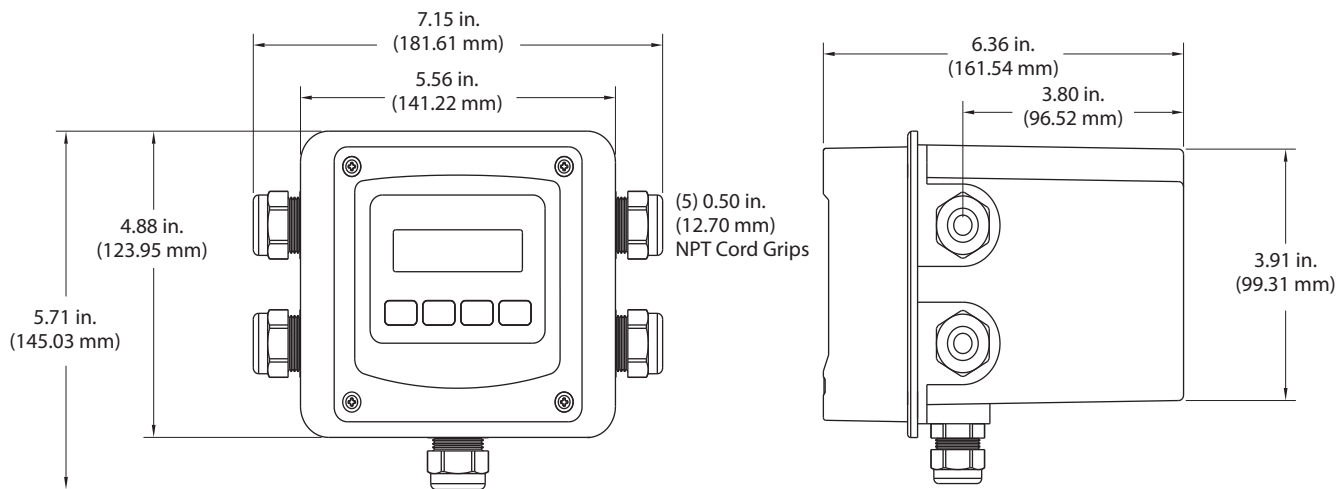

Figure 1: Q46 enclosure dimensions

## Wall or Pipe Mount

A PVC mounting bracket with attachment screws is supplied with each transmitter. The multipurpose bracket is attached to the rear of the enclosure using the four flat head screws. The instrument is then attached to the wall using the four outer mounting holes in the bracket. These holes are slotted to accommodate two sizes of U-bolts that may be used to pipe mount the unit. Slots accommodate U-bolts designed for 1-1/2 in. or 2 in. pipe. The actual center to center dimensions for the U-bolts are shown in [Figure 2](#).

**NOTE:** These slots are for U-bolts with 1/4-20 threads. The 1-1/2 in. pipe U-bolt (2 in. I.D. clearance) is available from Badger Meter in type 304 stainless steel under part number (47-0005).

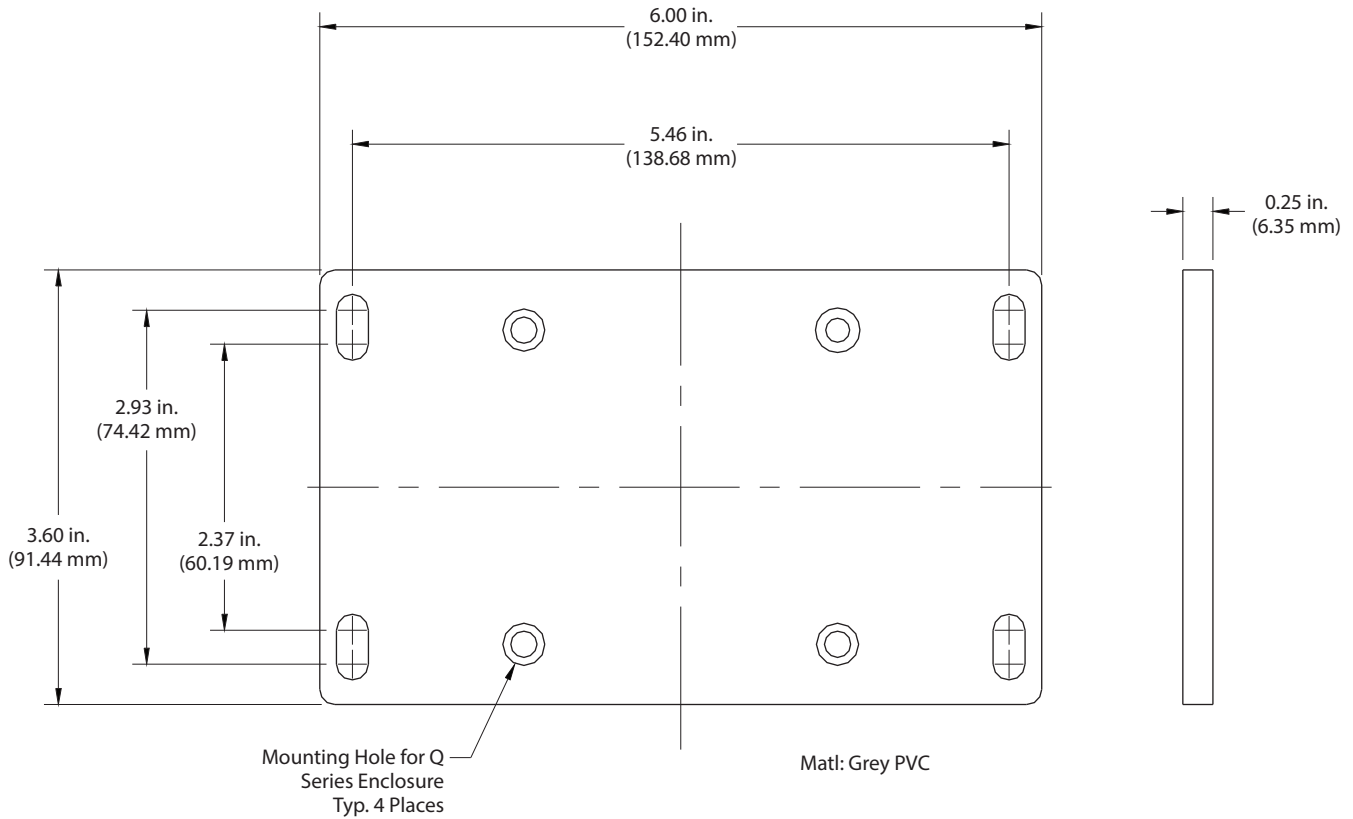
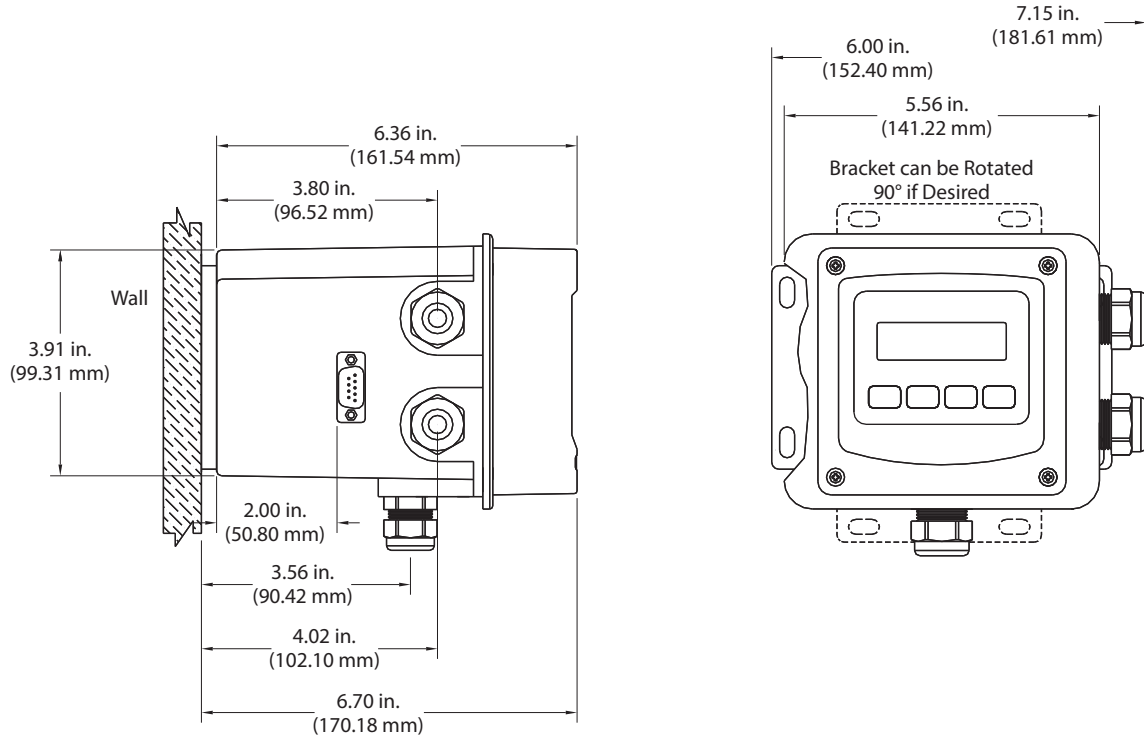

Figure 2: Wall or pipe mount bracket



**NOTE:** Analyzer shown with optional Profibus Connector mounted to side of enclosure.

Figure 3: Wall mounting diagram

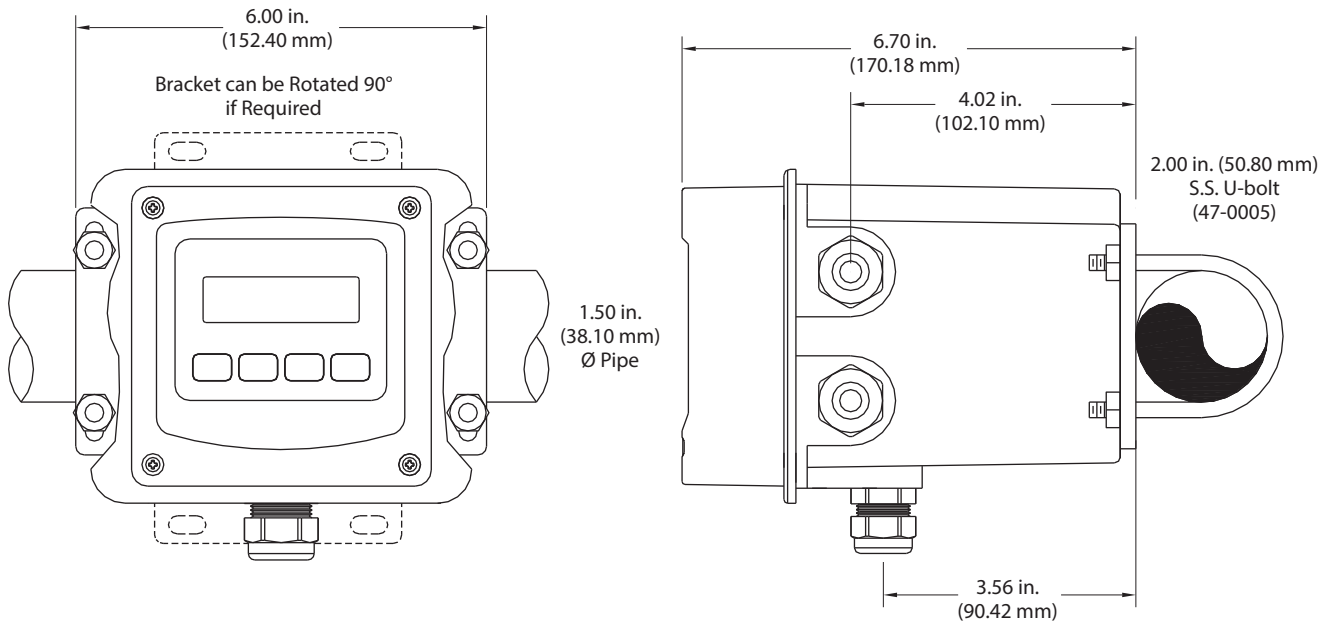

Figure 4: Pipe mounting diagram

## Panel Mount Monitor

Panel mounting uses the panel mounting flange molded into the rear section of the enclosure. *Figure 5* provides dimensions for the panel cutout required for mounting.

The panel mounting bracket kit must be ordered separately (part number 05-0094). This kit contains a metal retainer bracket that attaches to the rear of the enclosure, 4 screws for attachment of this bracket and a sealing gasket to ensure that the panel mounted monitor provides a water tight seal when mounted to a panel.

The sealing gasket must first be attached to the enclosure. The gasket contains an adhesive on one side so that it remains in place on the enclosure. Remove the protective paper from the adhesive side of the gasket and slide the gasket over the back of the enclosure so that the adhesive side lines up with the back of the enclosure flange. Once in place, you can proceed to mount the monitor in the panel.

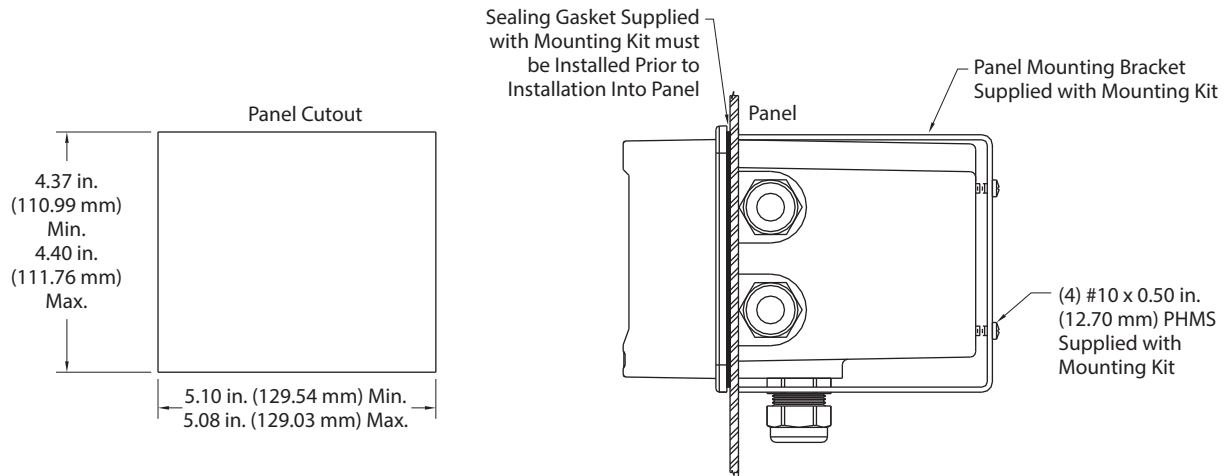

Figure 5: AC power panel mount cutout

## SENSOR MOUNTING

### General

The Q25CT Conductivity Sensor is designed for industrial and municipal process applications. Mounting options include flow-through or submersion. The sensor-to-analyzer distance must not exceed 200 ft (60 m).

In submersion applications, there must be a minimum of 2 in. clearance around and below the toroidal sensor. Placing the sensor close to wall or other objects results in a loss of accuracy.

Calibrate the sensor before placing it into the process. See ["Calibration" on page 40](#) for detailed calibration instructions.

See [Figure 6](#) for the dimensions of the toroidal sensor.

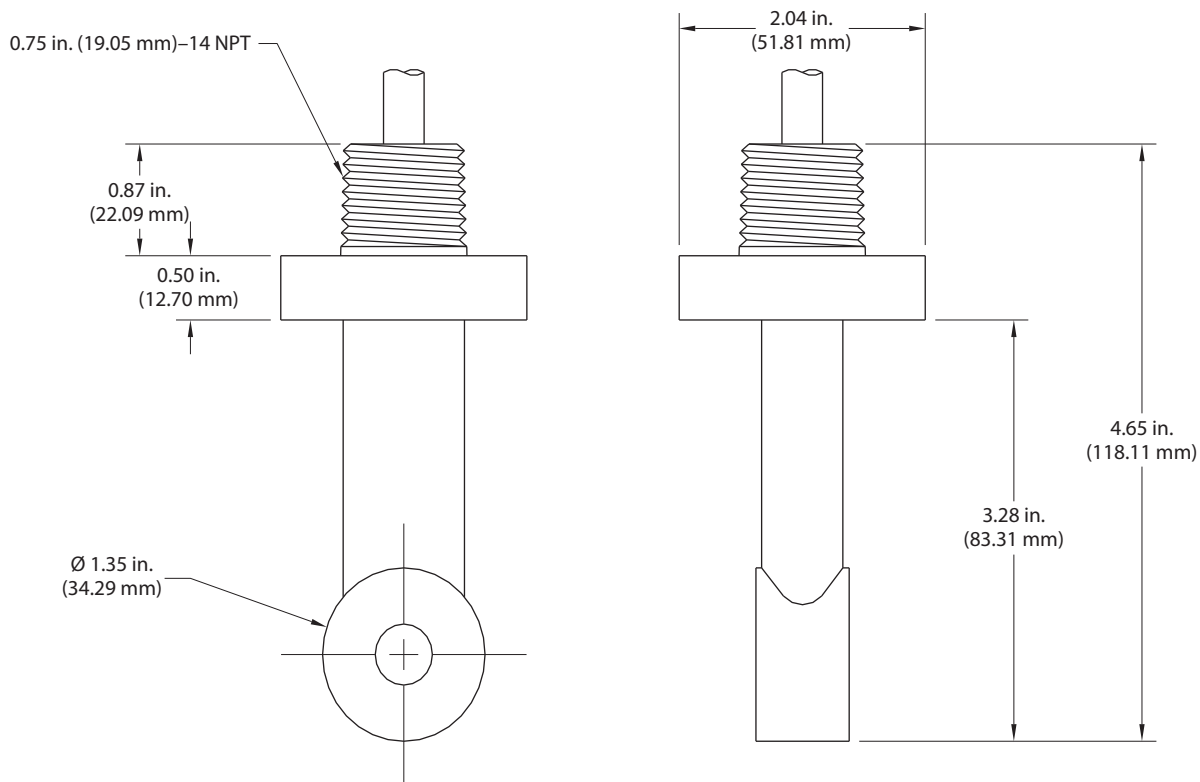

Figure 6: Toroidal sensor dimensions

## Tee Mounting

The toroidal sensors are mounted in a 2 in. pipe using an optional pipe adapter. The tee fitting is keyed so the sensor is oriented in the process as shown in [Figure 7](#). The sensor bore opening should be aligned so that flow passes directly through the open sensor bore. A positioning notch is located on the upper sensor collar to aid in this alignment. This orientation is used to ensure a representative sample is being measured and to keep the sensor bore clean.

**NOTE:** Sensor must be zero-calibrated before final mounting in tee.

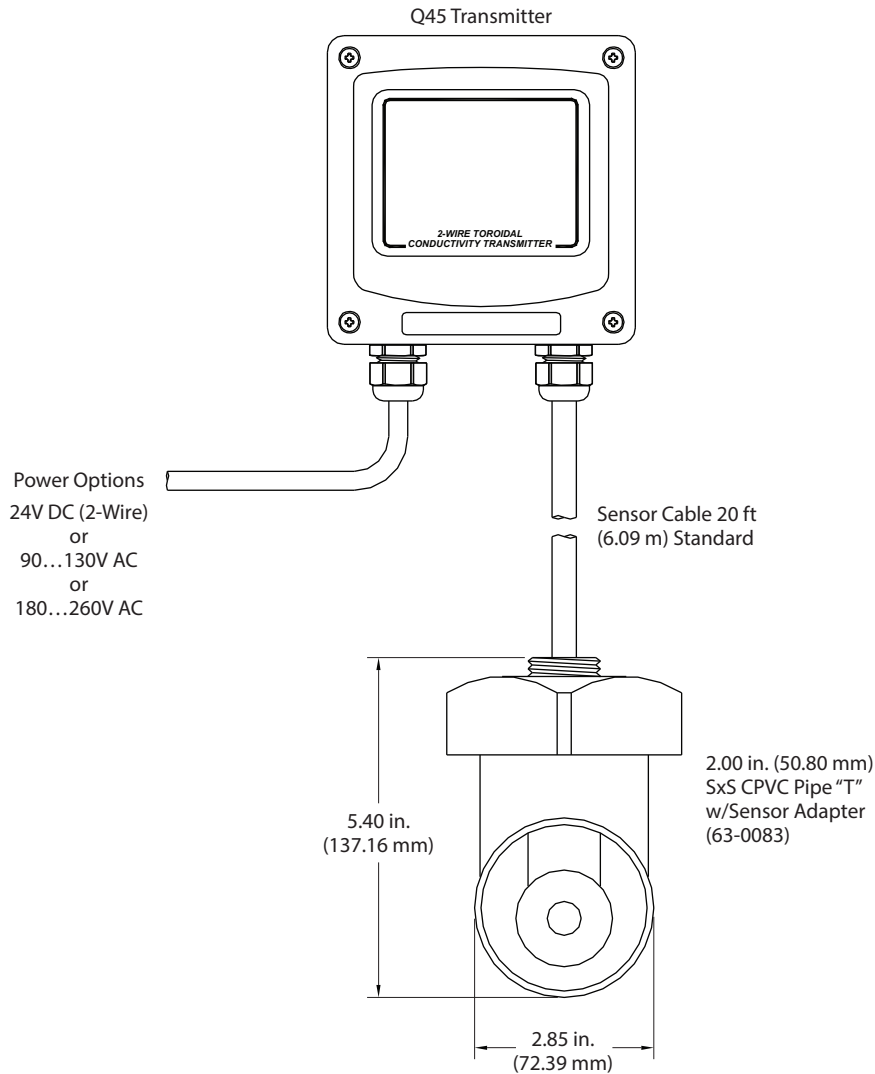

Figure 7: Sensor and flow tee assembly

## Submersion Mounting

When using this conductivity sensor for submersion applications, mount the sensor to the end of a 1 in. mounting pipe using a 1 in. coupling. Badger Meter's mounting assembly (00-0628) shown in [Figure 8](#) is available for submersible applications. This assembly is designed to mount to standard handrails and facilitates insertion and removal of the sensor.

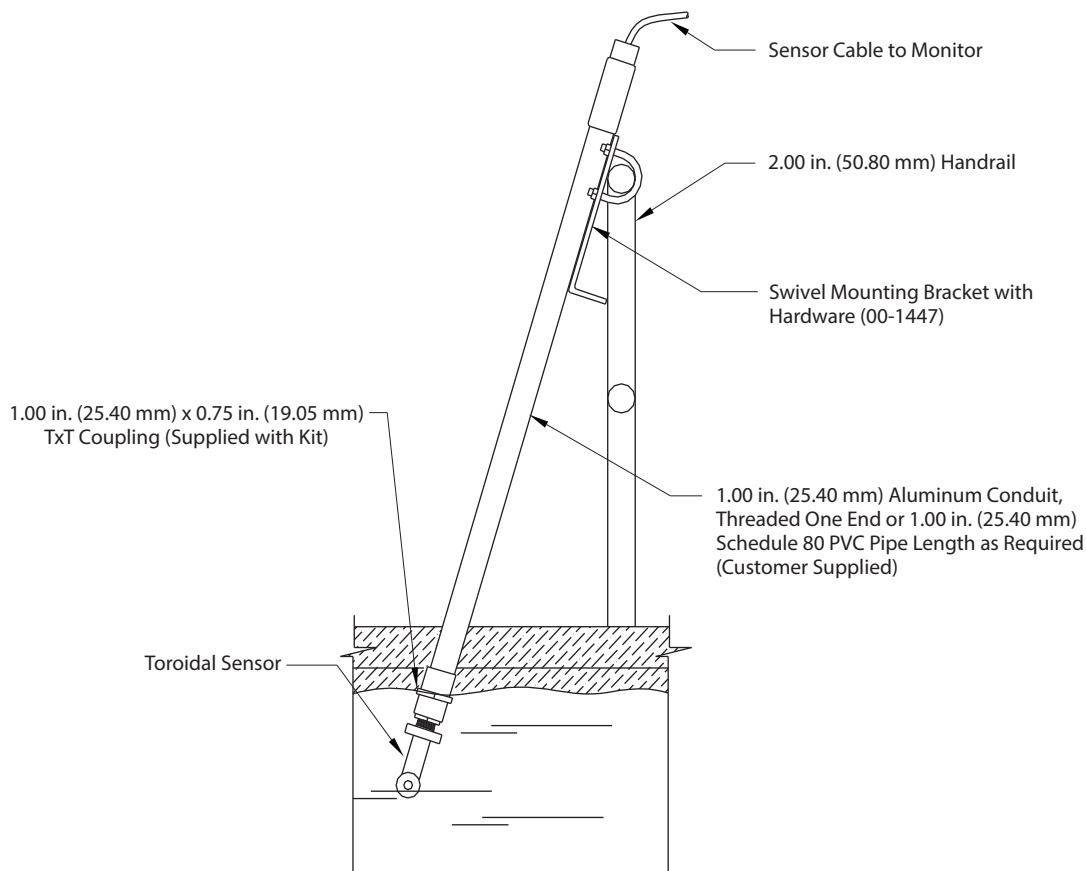

Figure 8: Sensor submersion mount

## In-Line Installation

Toroidal conductivity sensors may be installed directly into a flowing pipe system provided that the water does not contain a lot of entrained air. A 2 in. flow tee assembly is available for this purpose. It is best to install the sensor in a vertical pipe section with water flowing upward. This assures that air pockets cannot develop at the sensor. If installed in a horizontal run of pipe, place the sensor at the 3 or 9 o'clock position. Never mount the sensor on the top or bottom of the pipe. It is also good practice to install a bypass system around the sensor for maintenance and calibration purposes.

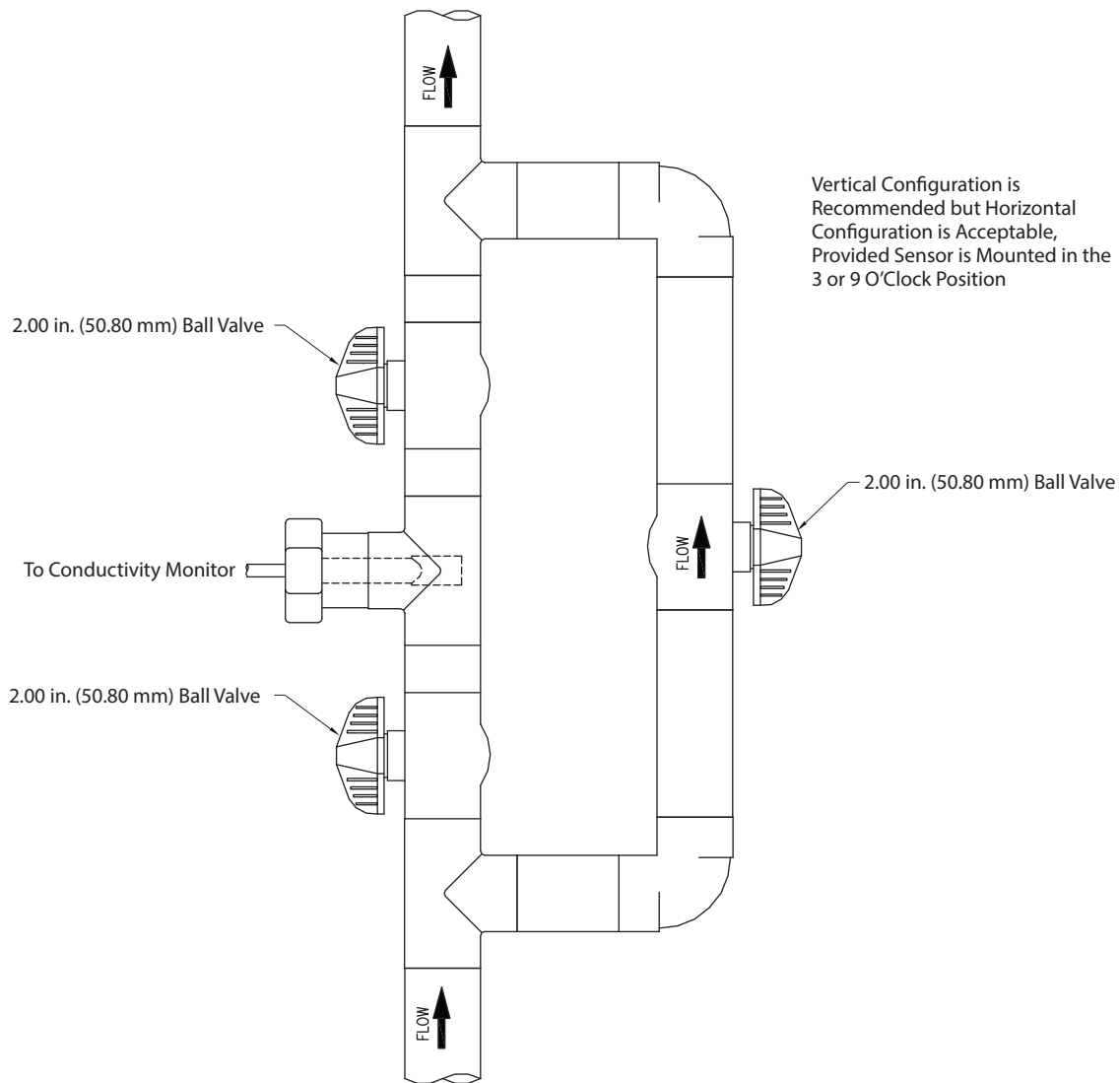

Figure 9: Flow tee process piping

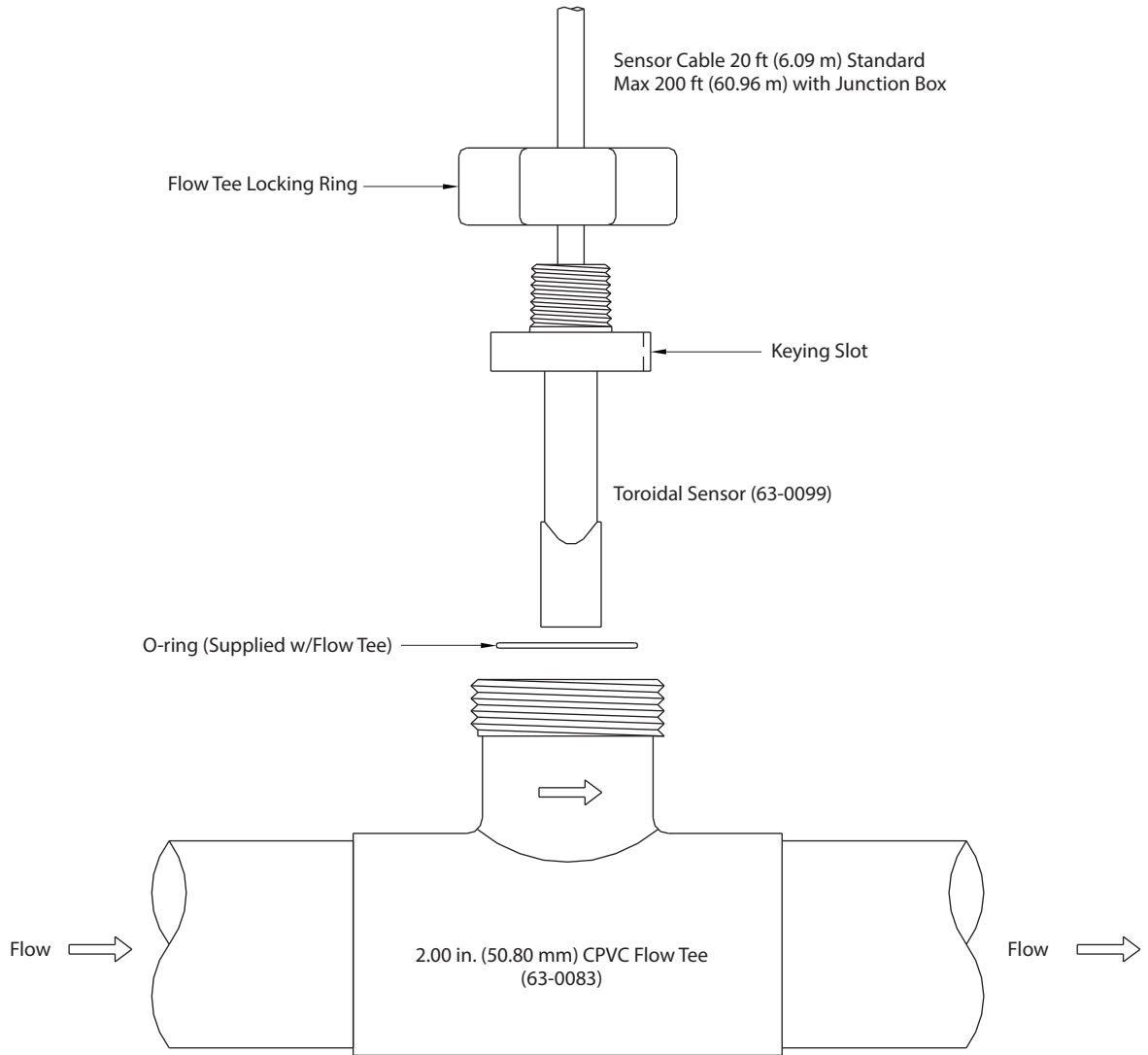

Figure 10: In-line process piping

## ELECTRICAL INSTALLATION

### General

The Q46 is powered in one of two ways, depending on the version purchased. The 12...24V DC powered analyzer requires a customer supplied DC power supply. The 90...260V AC version requires line power. Please verify the type of unit before connecting any power.

#### **WARNING**

**DO NOT CONNECT AC LINE POWER TO THE DC VERSION. SEVERE DAMAGE COULD RESULT.**

#### **IMPORTANT NOTES:**

1. Use wiring practices that conform to all national, state and local electrical codes. For proper safety as well as stable measuring performance, it is important that the earth ground connection be made to a solid ground point from **TB7**. The AC power supply contains a single 630 mA slo-blo fuse (Wickmann/Littlefuse part number 372-0630). The fuse **F1** is located adjacent to **TB7** and is easily replaceable.
2. Do NOT run sensor cables or instrument 4...20 mA output wiring in the same conduit that contains AC power wiring. AC power wiring should be run in a dedicated conduit to prevent electrical noise from coupling with the instrumentation signals.
3. This analyzer must be installed by specifically trained personnel in accordance with relevant local codes and instructions contained in this user manual. Observe the analyzer's technical specifications and input ratings. Proper electrical disconnection means must be provided prior to the electrical power connected to this instrument, such as a circuit breaker - rated 250V AC, 2 A minimum. If one line of the line power mains is not neutral, use a double-pole main switch to disconnect the analyzer.
4. Repeated problems with lightning strikes damaging sensitive instrumentation are often attributed to poorly bonded earth grounds in the instrument power source. The protection schemes incorporated into this analyzer cannot operate to maximum efficiency unless the ground connection is at its absolute lowest impedance.

There is no standard ground resistance universally recognized. Many agencies recommend a ground resistance value of 5 Ohms or less. The NEC recommends an impedance to ground of less than 25 Ohms and less than 5 Ohms where sensitive equipment is installed. Power sources feeding sensitive instruments like the Q46 should have the lowest possible impedance to ground.

## Power Connection

Verify the AC power supply requirement before installing. Also verify that power is fully disconnected before attempting to wire.

Q46 systems are supplied with 5 cable gland fittings for sealing cable entries.

Connect HOT, NEUTRAL and GROUND to the matching designations on terminal strip **TB7**.

### **WARNING**

**DISCONNECT LINE POWER VOLTAGE BEFORE CONNECTING LINE POWER WIRES TO TERMINAL TB7 OF THE POWER SUPPLY. THE POWER SUPPLY ACCEPTS ONLY STANDARD THREE-WIRE SINGLE PHASE POWER. AC POWER SUPPLIES ARE CONFIGURED FOR 100...240V AC OPERATION AT THE FACTORY AT TIME OF ORDER, AND THE POWER SUPPLY IS LABELED AS SUCH. DO NOT CONNECT VOLTAGES OTHER THAN THE LABELED REQUIREMENT TO THE INPUT.**

The two analog outputs for the standard system are present at terminal TB1. The loop-load limitation in this configuration is 500 Ohms maximum for each output.

**NOTE:** These two outputs are completely isolated from each other to ensure that ground loops do not result from the connection of both outputs to the same device such as a PLC or DCS.

A ribbon cable connects the power supply assembly with the microprocessor assembly located in the front section of the enclosure. This cable may be unplugged from the front section of the monitor if service is needed but should normally be left in place during installation.

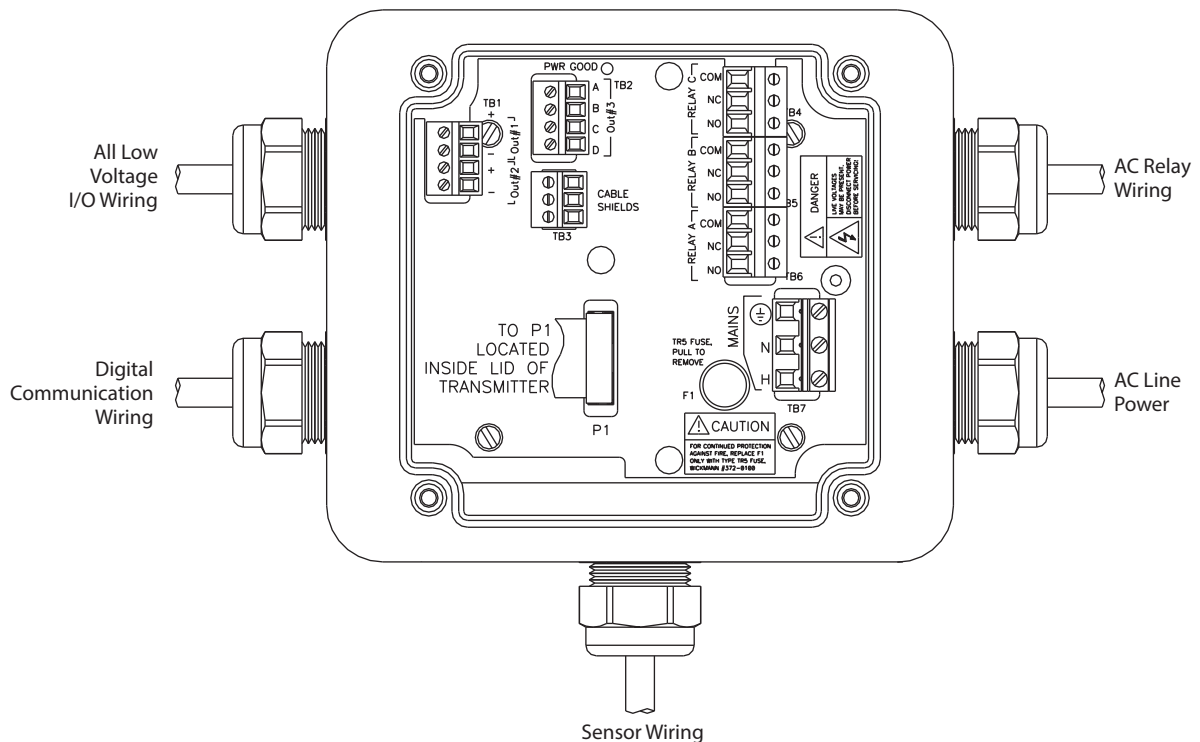

Figure 11: Q46 connection layout

## Relay Connection

Three SPDT relays are provided on the power supply board. None of the relay contacts are powered. The user must supply the proper power to the contacts. For applications that require the same switched operating voltage as the Q46 (115 or 230V), power may be jumpered from the power input terminals at **TB7**. Relay wiring is connected at **TB4**, **TB5** and **TB6** as shown in [Figure 12](#).

**NOTE:** The relay contact markings are shown in the *NORMAL* mode. Programming a relay for "Failsafe" operation reverses the NO and NC positions as shown in [Figure 12](#).

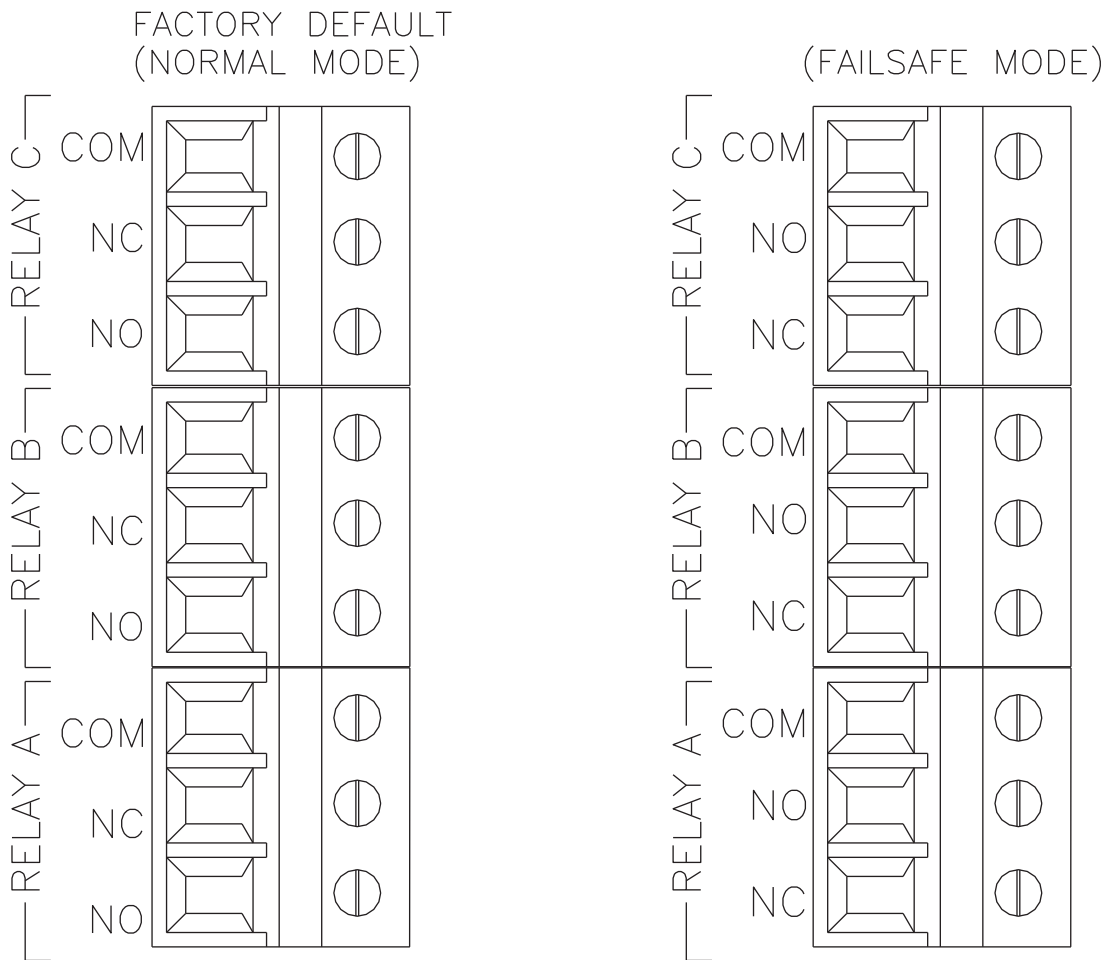

Figure 12: Relay connections

## Optional Output or Relay Connections

**TB2** is used to connect to the optional 3-relay card (*Figure 13*) **OR** the optional third analog output, Out#3 (*Figure 14*). The Q46 can be configured for only one of these optional features, and the hardware for either option must be factory installed.

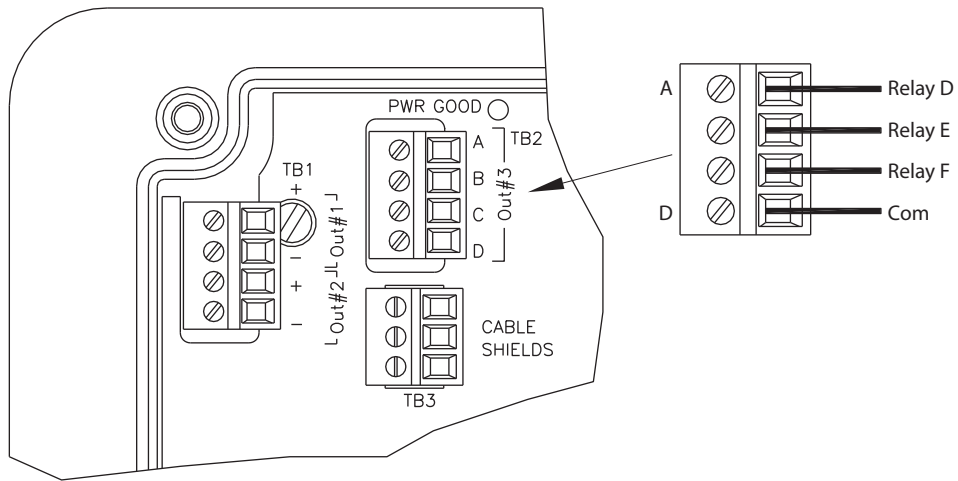

Figure 13: Optional relay board wiring

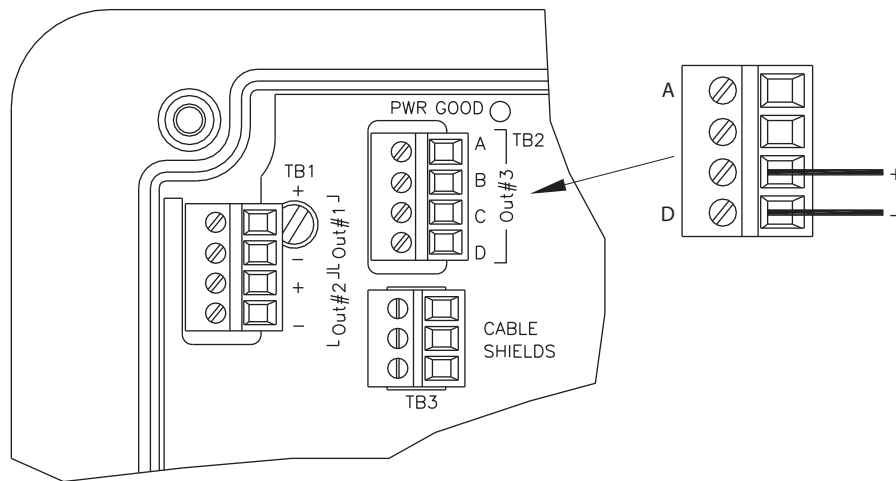

Figure 14: Optional analog output wiring

## Sensor Wiring

The sensor cable can be quickly connected to the Q46 terminal strip by matching the wire colors on the cable to the color designations on the label in the monitor. A junction box is also available to provide a break point for long sensor cable runs. Route signal cable away from AC power lines, adjustable frequency drives, motors or other noisy electrical signal lines. Do not run sensor or signal cables in conduit that contains AC power lines or motor leads.

**When installing conductivity monitors and sensors, we recommend keeping the sensor cable as short as is practical. This minimizes potential noise problems.**

### **⚠ DANGER**

**DO NOT CONNECT SENSOR CABLE TO POWER LINES. SERIOUS INJURY MAY RESULT.**

Take care to route sensor cable away from AC power lines, adjustable frequency drives, motors or other noisy electrical signal lines. Do not run signal lines in the same conduit as AC power lines. Run signal cable in dedicated metal conduit if possible. For optimum electrical noise protection, run an earth ground wire to the ground terminal in the transmitter.

See [Figure 11 on page 19](#) and [Figure 15 on page 23](#) for illustrative details on electrical installation.

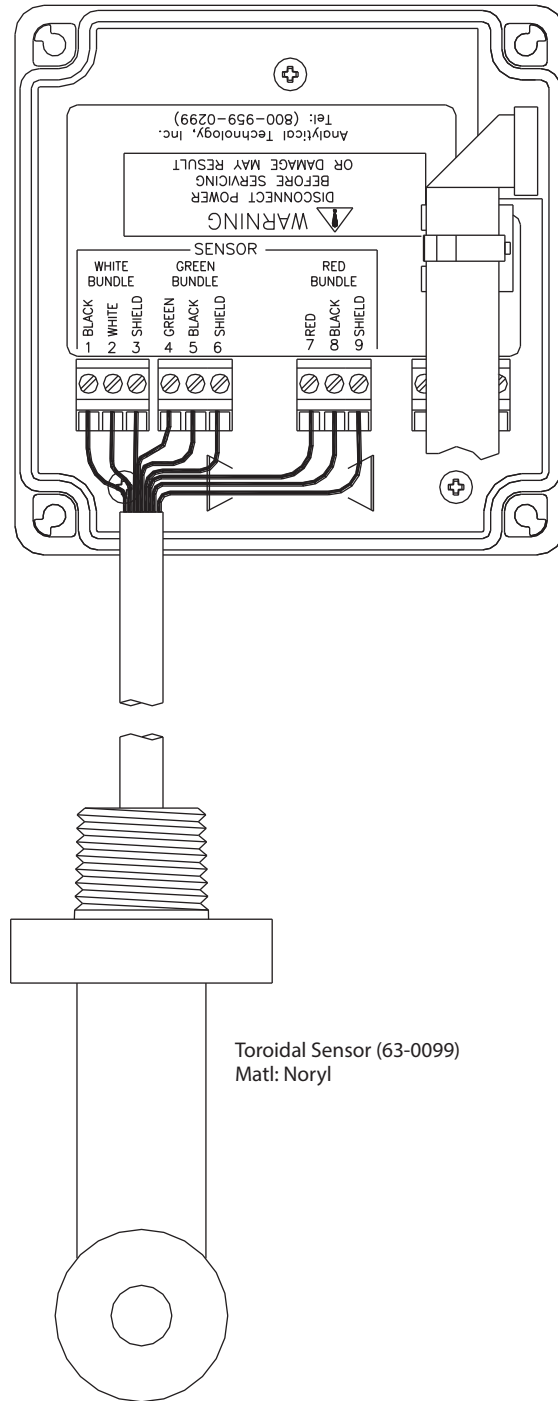

Figure 15: Q46CT sensor connections

## Direct Sensor Connection

Sensor connections are made in accordance with [Figure 15 on page 23](#). The sensor cable can be routed into the enclosure through one of the cord grips supplied with the unit. Routing sensor wiring through conduit is only recommended if a junction box is to be used. Some loose cable is needed near the installation point so that the sensor can be inserted and removed easily depending on the installation type.

Cord grips used for sealing the cable should be snugly tightened after electrical connections have been made to prevent moisture incursion. When stripping cables, leave adequate length for connections in the transmitter enclosure as shown in [Figure 16](#). The standard 20 ft sensor cable normally supplied with the system is already stripped and ready for wiring. This cable can be cut to a shorter length if desired to remove extra cable in a given installation. Do not cut the cable so short as to make installation and removal of the sensor difficult.

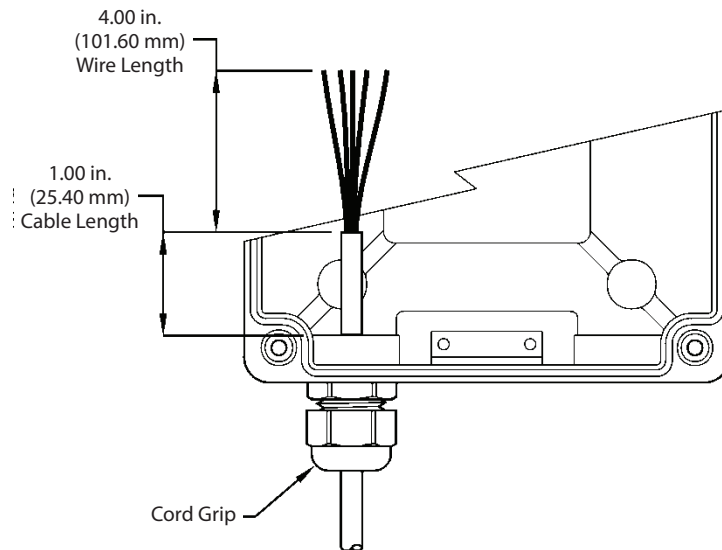

Figure 16: Sensor cable preparation

## Junction Box Connection

When sensor separation from the monitor is needed and to be greater than 20 ft, the sensor junction box (07-0100) is required. Wire according to [Figure 17](#) with 3 paired, individually shielded 22 AWG cable (31-0068).

### CAUTION

**WHEN USING A JUNCTION BOX AND SENSOR INTERCONNECT CABLE, THE RED SHIELD MUST BE ISOLATED FROM THE WHITE AND GREEN SHIELDS. FAILURE TO MAINTAIN ISOLATION WITH THE RED SHIELD COULD RESULT IN MEASUREMENT INSTABILITY.**

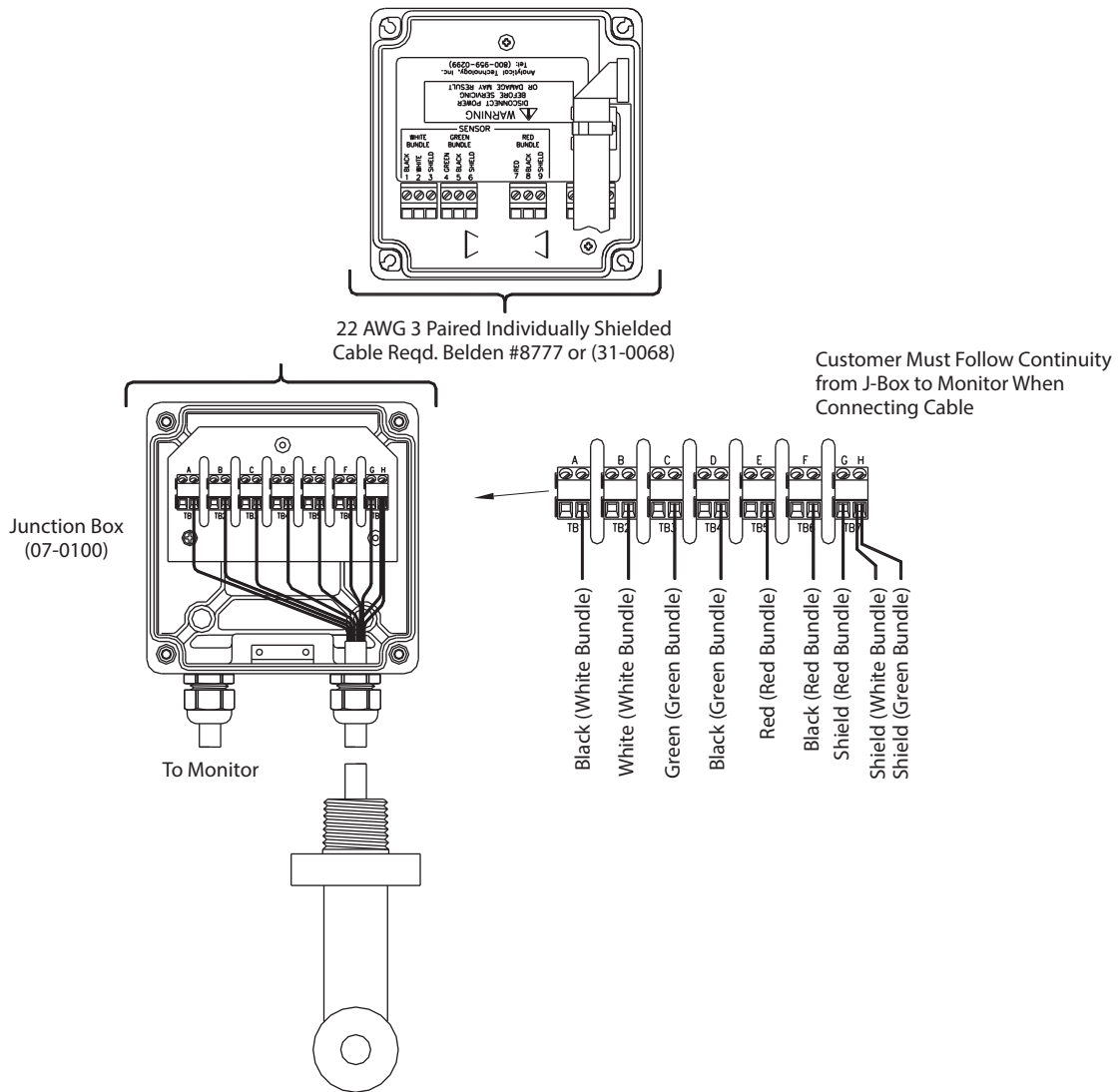

Figure 17: Junction box interconnect wiring

## CONFIGURATION

### User Interface

The user interface for the Q46 Series instrument consists of a custom display and a membrane keypad. All functions are accessed from this user interface (no internal jumpers or pots, for example).

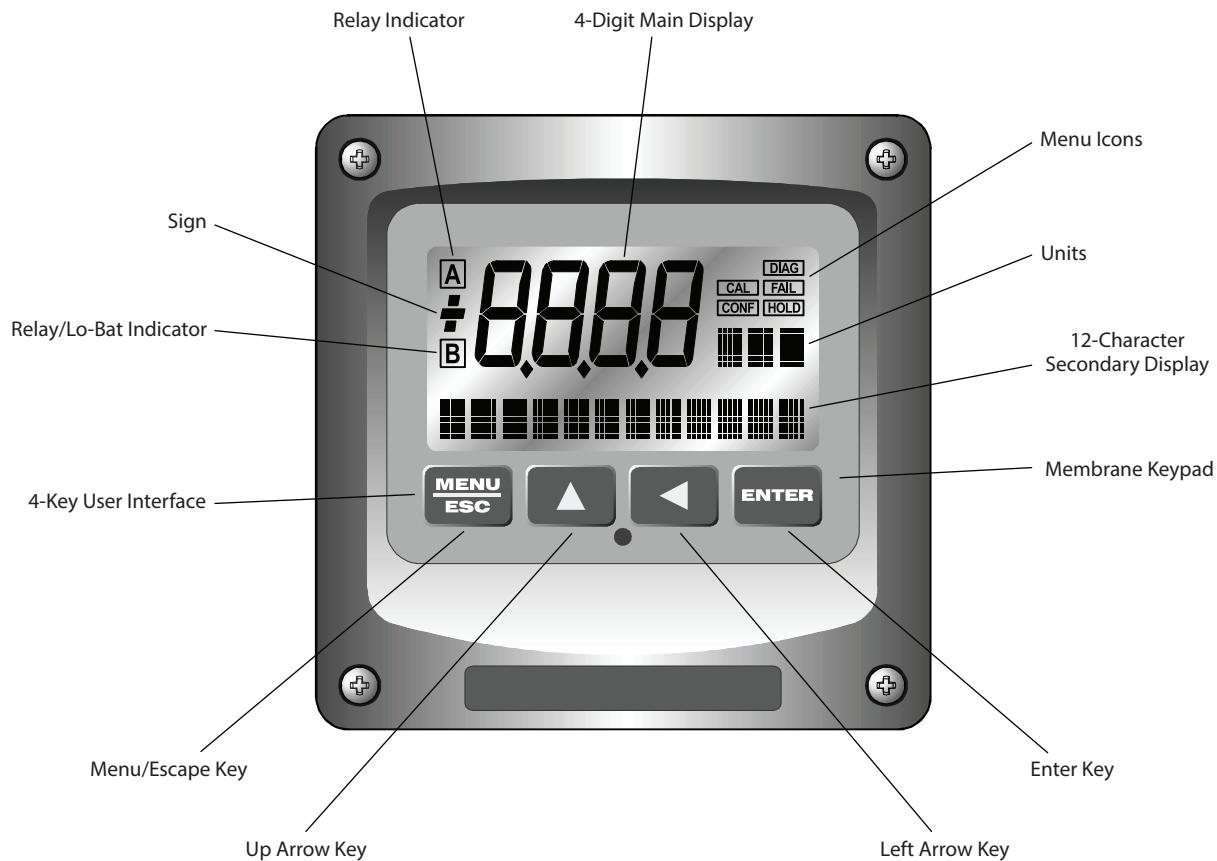

Figure 18: User interface

### Keys

All user configurations occur through the use of four membrane keys. These keys are used as follows:

<b>MENU/ESC</b>	To scroll through the menu section headers or to escape from anywhere in software. The escape sequence allows the user to back out of any changes in a logical manner. Using the escape key aborts all changes to the current screen and backs the user out one level in the software tree. The manual refers to this key as either MENU or ESC, depending upon its particular function.
<b>UP (arrow)</b>	To scroll through individual list or display items and to change number values.
<b>LEFT (arrow)</b>	To move the cursor from right to left during changes to a number value.
<b>ENTER</b>	To select a menu section or list item for change and to store any change.

## Display

The large custom display provides clear information for general measurement use and user configuration. There are three main areas of the display: the main parameter display, the secondary message line and the icon area.

**Main Parameter** During normal operation, the main parameter display indicates the present process input with sign and units. This main display may be configured to display any of the main measurements that the system provides. During configuration, this area displays other useful set-up information to the user.



**Lower Line** During normal operation, the lower line of the display indicates user-selected secondary measurements that the system is making. This also includes calibration data from the last calibration sequence and the transmitter model number and software version. During configuration, the lower line displays menu items and set-up prompts to the user. Finally, the lower line displays error messages when necessary. For a description of all display messages, see ["Display Messages" on page 48](#).

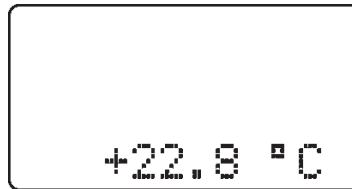

**Icon Area** The icon area contains display icons that assist the user in set-up and indicate important states of system functions. The *CAL*, *CONFIG*, *CNTRL* and *DIAG* icons are used to tell the user what branch of the software tree the user is in while scrolling through the menu items. This improves software map navigation dramatically. Upon entry into a menu, the title is displayed (such as *CAL*), and then the title disappears to make way for the actual menu item. However, the icon stays on.



**HOLD** The *HOLD* icon indicates that the current output of the transmitter has been put into output hold. In this case, the output is locked to the last input value measured when the *HOLD* function was entered. *HOLD* values are retained even if the unit power is cycled.

**FAIL** The *FAIL* icon indicates that the system diagnostic function has detected a problem that requires immediate attention. This icon is automatically cleared once the problem has been resolved.

**Relay Area A/B** The relay area contains two icons that indicate the state of the system relays. Relay C is normally configured for *FAIL* indication, so it is only displayed on the lower *MEASURE* display line.

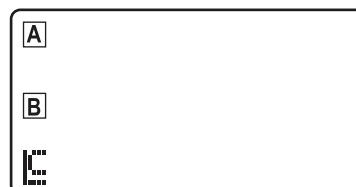

## Software

The software of the Q46CT is organized in an easy to follow menu-based system. All user settings are organized under five menu sections: *Measure*, *Calibration [CAL]*, *Configuration [CONFIG]*, *Control [CONTROL]* and *Diagnostics [DIAG]*.

**NOTE:** The default *Measure* menu is display-only and has no menu icon.

### Software Navigation

Within the *CAL*, *CONFIG*, *CONTROL* and *DIAG* menu sections is a list of selectable items. Once a menu section (such as *CONFIG*) has been selected with the MENU key, the user can access the item list in this section by pressing either the **ENTER** key or the **UP** arrow key. The list items can then be scrolled through using the **UP** arrow key. Once the last item is reached, the list wraps around and the first list item is shown again. The items in the menu sections are organized such that more frequently used functions are first, while more permanent function settings are later in the list. See [Figure 19 on page 29](#) for a visual description of the software.

Each list item allows a change to a stored system variable. List items are designed in one of two forms: simple single variable, or multiple variable sequence. In the single variable format, the user can quickly modify one parameter. For example, changing temperature display units from °F to °C. In the multiple variable sequence, variables are changed as the result of some process. For example, the calibration of conductivity generally requires more than one piece of information to be entered. The majority of the menu items in the software consist of the single variable format type.

Any data that may be changed flashes. This flashing indicates *User Entry* mode and is initiated by pressing the **ENTER** key. The **UP** arrow key increases a flashing digit from 0...9. The **LEFT** arrow key moves the flashing digit from right to left. Once the change has been completed, pressing **ENTER** again stores the variable and stops the flashing. Pressing **ESC** aborts the change and also exits *User Entry* mode.

The starting (default) screen is always the *Measure* menu. The **UP** arrow key is used to select the desired display. From anywhere in this section the user can press the **MENU** key to select one of the four menu sections.

The UP arrow icon next to all list items on the display is a reminder to scroll through the list using the **UP** arrow key.

To select a list item for modification, first select the proper menu with the **MENU** key. Scroll to the list item with the **UP** arrow key and then press the **ENTER** key. This tells the system that the user wishes to perform a change on that item. For single item type screens, once the user presses the **ENTER** key, part or all of the variable begins to flash, indicating that the user may modify that variable using the arrow keys. However, if the instrument is locked, the transmitter displays the message "Locked!" and does not enter *User Entry* mode. The instrument must be unlocked by entering the proper code value to allow authorized changes to user entered values. Once the variable has been reset, pressing the **ENTER** key again causes the change to be stored and the flashing to stop. The message "Accepted!" displays if the change is within pre-defined variable limits. If the user decides not to modify the value after it has already been partially changed, pressing the **ESC** key aborts the modification and returns the entry to its original stored value.

In a menu item that is a multiple variable sequence type, once the **ENTER** key is pressed there may be several prompts and sequences that are run to complete the modification. The **ESC** key can always be used to abort the sequence without changing any stored variables.

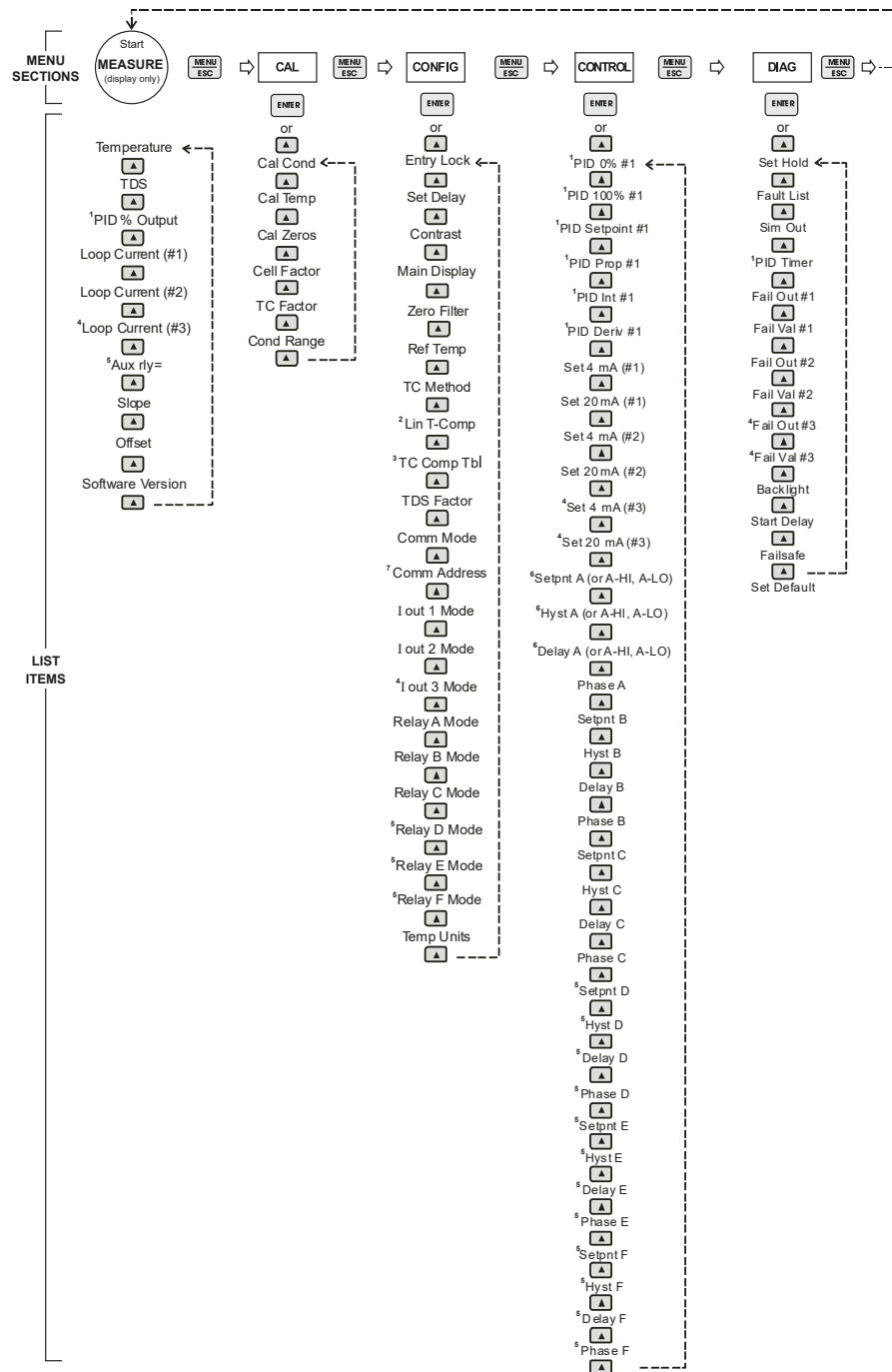

**NOTE:** (1) If Relay A, B, C, D, E, F is set to *FAIL* mode, relay settings are not displayed in menu.  
 (2) The annunciator for Relay C is shown in the *MEASURE*/temperature display.

- 1 PID is enabled.
- 2 Linear Temp Comp selected.
- 3 Table Temp Comp selected.
- 4 Optional third 4...20 output installed.
- 5 Optional 3-relay card installed (D, E, F).
- 6 If Relay A is set to *ALARM* mode, the settings are divided into 2 groups of HI and LO points.
- 7 If *Comm* mode is set to a selection other than none, additional *Comm* menus show.

Figure 19: Software map

## Measure Menu [MEASURE]

The default menu for the system is the display-only menu *MEASURE*. This menu is a display-only measurement menu and has no changeable list items. When left alone, the instrument automatically returns to this menu after approximately 30 minutes. While in the default menu, the UP arrow key allows the user to scroll through the secondary variables on the lower line of the display. A brief description of the fields in the basic transmitter version is as follows:

### Transmitter Measure Screens:

<b>25.7° C</b>	Temperature display. Can be displayed in °C or °F, depending on user selection. A small “m” to the left side of the temperature indicates the transmitter has automatically jumped to a manual 25° C setting due to a failure with the temperature signal input. An L <sup>C</sup> symbol to the left of the temperature appears if Relay C activates.
<b>TDS = 200 ppm</b>	Total Dissolved Solids (TDS). Displays TDS of process.
<b>100% 20.00 mA</b>	<i>PID Status</i> screen (if enabled) shows the present controller output level on the left, and actual transmitter current on the right. The controller can be placed in manual while viewing this screen by pressing and holding the <b>ENTER</b> key for 5 seconds until a small flashing “m” appears on the screen. At that point the controller output can be adjusted up or down using the <b>UP</b> and <b>LEFT</b> arrow keys. To return to automatic operation, press and hold the <b>ENTER</b> key for 5 seconds and the “m” disappears.
<b>#1 4.00 mA</b>	Analyzer output current #1.
<b>#2 12.00 mA</b>	Analyzer output current #2.
<b>#3 20.00 mA</b>	Analyzer output current #3 (if option included).
<b>Aux relay = D,E,F</b>	Auxiliary relay annunciators (if option included).
<b>Slope</b>	The slope is an indication of the sensor output as compared to the theoretical output if the sensor were perfect. The slope value is calculated after completion of a calibration as described in <a href="#">“Calibration” on page 40</a> .
<b>Q46CT v4.00</b>	Transmitter software version number.

**NOTE:** A display test (all segments ON) can be actuated by pressing and holding the **ENTER** key while viewing the model/version number on the lower line of the display.

The *MEASURE* screens are intended to be used as a very quick means of looking up critical values during operation or troubleshooting.

## Calibration Menu [CAL]

The calibration menu contains items for frequent calibration of user parameters. There are six items in this list: *Cal Cond*, *Cal Temp*, *Cal Zeros*, *Cell Factor*, *TC Factor* and *Cond Range*.

- Cal Cond** The conductivity calibration function allows the user to adjust the transmitter offset and span reading to match reference buffers or to adjust the sensor offset to match the sample reading. See “*Calibration*” on [page 40](#) for more details.
- Cal Temp** The temperature calibration function allows the user to adjust the offset of the temperature response by a small factor of  $\pm 5^\circ$  C. The temperature input is factory calibrated to very high accuracy. However, long cable lengths and junction boxes may degrade the accuracy of the temperature measurement in some extreme situations. Therefore, this feature is provided as an adjustment. See “*Calibration*” on [page 40](#) for more details.
- Cal Zeros** This function calibrates all range zero-points to the specific sensor being used. This function is only required to be performed once at initial startup or when the sensor has been replaced. See “*Calibration*” on [page 40](#) for more details.
- Cell Factor** This function allows the user to directly enter the factory measured cell constant for the Q25CT sensor. When this feature is used, calibration with reference solutions is not necessary. The default setting is 1.00.  
**NOTE:** This value is actually calculated from an actual liquid calibration, so running a conductivity calibration changes this value.
- TC Factor** This function allows the user to directly enter the factory measured temperature offset value marked on the sensor label. The default for this setting is 7.50 and most sensors are fairly close to that number.
- Cond Range** This function allows the user to set the display range of the transmitter for a specific application. Once set, all output functions use this display range to establish configuration settings. The default range is 0...200.0 mS. Press **ENTER** to initiate *User Entry* mode, and the value flashes. Use the arrow keys to modify the range for the desired range and then press **ENTER**.

## Configuration Menu [CONFIG]

The *Configuration* menu contains all of the general user settings:

- Entry Lock** This function allows the user to lock out unauthorized tampering with instrument settings. All settings may be viewed while the instrument is locked, but they cannot be modified. The *Entry Lock* feature is a toggle-type setting; that is, entering the correct code locks the transmitter and entering the correct code again unlocks it. The code is preset at a fixed value. Press **ENTER** to initiate *User Entry* mode and the first digit flashes. Use the arrow keys to modify value. See [page 50](#) for the Q46CT lock/unlock code. Press **ENTER** to toggle lock setting once code is correct. Incorrect codes do not change state of lock condition.
- Set Delay** The delay function sets the amount of damping on the instrument. This function allows the user to apply a first order time delay function to the conductivity measurements being made. Both the display and the output value are affected by the degree of damping. Functions such as calibration are not affected by this parameter. The calibration routines contain their own filtering and stability monitoring functions to minimize the calibration timing. Press **ENTER** to initiate *User Entry* mode, and the value flashes. Use the arrow keys to modify value; range is 0.1...9.9 minutes. Press **ENTER** to store the new value.
- Contrast** This function sets the contrast level for the display. The custom display is designed with a wide temperature range, Super-Twist Nematic (STN) fluid. Press **ENTER** to initiate *User Entry* mode, and the value flashes. Use the arrow keys to modify the value; range is 0...8 (0 being lightest). Press **ENTER** to update and store the new value.
- Main Display** This function allows the user to change the measurement in the primary display area, selecting between conductivity or auto-ranging conductivity.  
Press **ENTER** to initiate *User Entry* mode, and the entire value flashes. Use the **UP** arrow key to modify the desired display value. Press **ENTER** to store the new value.

- Zero Filter** This function forces the reading to zero when reading is below the entered value. For example, if the entered value were 2.1 mS, the display would read 0.0 mS when the measured value reached 2.0 mS. This feature is useful in blanking out very small and meaningless zero variability.
- Ref Temp** The reference temperature function sets the basis point for the linear temperature compensation methods. In most cases this setting should be left at the default of 25.0° C.  
Press **ENTER** to initiate *User Entry* mode, and the entire value flashes. Use the arrow keys to modify the desired value; range is 0.0...50.0° C. Press **ENTER** to update and store the new value. This setting appears in the *Software* menu only if *Temp* mode is set to **Lin**.
- TC Method** This function allows selection of the method used for the temperature compensation in the instrument. The choices are **1-Lin** or **2-Table**. The Lin (linear) method is by far the most common and should be used unless special measurements are being made.  
Under the **2-Table** selection, you have the ability to enter your own custom temperature compensation table. You can enter up to 6 multipliers from your own temperature compensation data if required for special applications.  
**NOTE:** Do not set the *Temp* mode to a value other than **Lin** unless you are confident in the temperature data developed for your special application.
- Lin T-Comp** This function sets the correction slope value for the linear temperature compensation and is used when the "Temp Mode" is set to **Lin**. Linear compensation is recommended for most aqueous solutions, and the value is typically 2.00%/°C (25° C reference temperature) for neutral water. This is the factory default and it provides the best compensation for most aqueous solutions. Other typical ranges include:  
Acids: 1.0...1.6%/°C  
Bases: 1.8...2.0%/°C  
Salts: 2.2...3.0%/°C  
**NOTE:** If the temperature units are changed between °C and °F (see "*Temp Units*" on page 33), the default setting for this output changes between 2.00%/°C...1.11%/°F accordingly.  
Other compensation slopes for uncommon solutions may be found in chemical handbooks (such as the CRC). Press **ENTER** to initiate *User Entry* mode, and the entire value flashes. Use the arrow keys to modify the desired value; entry range is 0.000%/°C (no compensation)...4.000%/°C. Press **ENTER** to store the new value.
- TDS Factor** This function sets the linear relationship of the TDS (Total Dissolved Solids) reading to the conductivity measurement. The actual units for the slope are in mg/L/μS. The default value is 00.49 mg/L/μS.  
Press **ENTER** to initiate *User Entry* mode, and the entire value flashes. Use the arrow keys to modify the desired value; range is 00.00 mg/L/μS...99.99 mg/L/μS. Press **ENTER** to update and store the new value.
- Com Mode** Sets digital communication mode of analyzer. Optional digital communication card must be plugged into the power supply slot for this function to work. Press **ENTER** to initiate *User Entry* mode, and the entire value flashes. Use the **UP** arrow key to modify the desired value; selections include 1 – None, 2 – P-DP for Profibus DP, 3 – Modbus or 4 – Ethernet IP. Press **ENTER** to store the new value.
- Com Address** Sets bus address for digital communication mode of analyzer. Optional digital communication card must be plugged into the power supply slot for this function to work. Press **ENTER** to initiate *User Entry* mode, and the entire value flashes. Use the **UP** arrow key to modify the desired value. Range is 1...125. Press **ENTER** to store the value.
- Iout#1 Mode** This assigns the 4...20 mA output #1 to either μS (by selecting 1) or for PID output (by selecting 2).
- Iout#2 Mode** This assigns the 4...20 mA output #2 to temperature (by selecting 1), μS (by selecting 2) or TDS mg/L (by selecting 3).
- \*Iout#3 Mode** **OPTIONAL.** This function sets analog output #3 for temperature, conductivity or TDS. Press **ENTER** to initiate *User Entry* mode, and the entire value flashes. Use the **UP** arrow key to modify the desired value; selections include 1 – °C/°F for temperature, 2 – μS or 3 – mg/L. Press **ENTER** to store the new value.

- Relay A Mode** Relay A can be used in three different ways: as a setpoint control, as a fail alarm or as a HI-LO alarm band. The three settings for Relay A mode are *CON*, *FAIL* and *AL*.
- The *CON* setting enables normal control operation for Relay A, with settings for setpoint, hysteresis, delay and phasing appearing in the *CONFIG* menu automatically. See [Figure 20 on page 35](#) for further details.
- The *FAIL* setting enables the fail alarm mode for Relay A. Relay A then trips on any condition that causes the *FAIL* icon to be displayed on the LCD. Using this mode allows the user to send alarm indications to other remote devices.
- The *AL* setting allows two setpoints to be selected for the same relay, producing a HI-LO alarm band. In this mode, Relay A trips inside or outside of the band, depending upon the phase selected. See [Figure 21 on page 36](#) for further details.
- Relay B Mode** Relay B and C can be used in two ways: as a setpoint control, or as an alarm. The two settings for Relay B and C modes are *CON* and *FAIL*. Relay B and C are also set up for 2 “clean modes”, but these modes are generally not used for toroidal conductivity. They are used to activate automatic sensor cleaning systems that are generally not required.
- Relay C Mode** The *CON* setting enables normal setpoint operation for Relay B/C. Relay B/C then operates identically to Relay A, with settings for setpoint, hysteresis, delay and phasing appearing in the *CONFIG* menu automatically.
- The *FAIL* setting enables the fail alarm mode for Relay B/C. Relay B/C then trips on any condition that causes the *FAIL* icon to be displayed on the LCD.
- NOTE:** The Relay C indicator shows up only on the lower screen of the display next to the temperature reading. This is because the default setting for Relay C is the *FAIL* setting. Using this mode allows the user to send alarm indications to other remote devices.
- \*Relay D Mode** **OPTIONAL.** Relays D, E and F can be used in two ways: as a setpoint control or as an alarm. The two settings for Relays D, E and F modes are *CON* and *FAIL*.
- \*Relay E Mode**
- \*Relay F Mode** The *CON* setting enables normal setpoint operation for Relays D, E and F. Relays D, E and F then operate identically to Relay A, with settings for setpoint, hysteresis, delay and phasing appearing in the *CONFIG* menu automatically.
- Temp Units** This function sets the display units for temperature measurement. Press **ENTER** to initiate *User Entry* mode, and the entire value flashes. Use the **UP** arrow key to modify the desired display value. The choices are **°F** and **°C**. Press **ENTER** to store the new value.

## Control Menu

The *Control* menu contains all of the output control user settings.

<p><b>Set PID 0%</b> <b>Set PID 100%</b> [lout1=PID]</p>	<p>If the PID is enabled, this function sets the minimum and maximum controller end points. Unlike the standard 4...20 mA output, the controller does not “scale” output values across the endpoints. Rather, the endpoints determine where the controller would normally force minimum or maximum output in an attempt to recover the setpoint (even though the controller can achieve 0% or 100% anywhere within the range).</p> <p>If the 0% point is lower than the 100% point, then the controller action “reverse” acts. That is, the output of the controller increases if the measured value is less than the setpoint, and the output decreases if the measured value is larger than the setpoint. Flipping the stored values in these points reverses the action of the controller to “direct” mode.</p> <p>The entry value is limited to a value within the range specified in “Set Range”, and the 0% and the 100% point must be separated by at least 1% of this range. Use the <b>LEFT</b> arrow key to select the first digit to be modified. Then use the <b>UP</b> and <b>LEFT</b> arrow keys to select the desired numerical value. Press <b>ENTER</b> to store the new value.</p>
<p><b>PID Setpnt</b> [lout1=PID]</p>	<p>The measured value which the controller is attempting to maintain by adjusting output value. It is the nature of the PID controller that it never actually gets to the exact value and stops. The controller is continually making smaller and smaller adjustments as the measured value gets near the setpoint.</p>
<p><b>PID Prop</b> [lout1=PID]</p>	<p>Proportional gain factor. The proportional gain value is a multiplier on the controller error (difference between measured value and setpoint value). Increasing this value makes the controller more responsive.</p>
<p><b>PID Int</b> [lout1=PID]</p>	<p>Integral is the number of “repeats-per-minute” of the action of the controller. It is the number of times per minute that the controller acts on the input error. At a setting of 2.0 rpm, there are two repeats every minute. If the integral is set to zero, a fixed offset value is added to the controller (manual reset). Increasing this value makes the controller more responsive.</p>
<p><b>PID Deriv</b> [lout1=PID]</p>	<p>Derivative is a second order implementation of Integral, used to suppress “second-order” effects from process variables. These variables may include items like pumps or mixers that may have minor impacts on the measured value. The derivative factor is rarely used and therefore, it is best in most cases to leave it at the default value. Increasing this value makes the controller more responsive.</p>
<p><b>Set 4 mA (#1)</b> <b>Set 20 mA (#1)</b> [lout1=conductivity]</p>	<p>These functions set the main 4 and 20 mA current loop #1 output points for the analyzer when output 1 is in normal, non-PID, mode of operation. The value stored for the 4 mA point may be higher or lower than the value stored for the 20 mA point. The entry values are limited to values within the range specified in “Set Range”, and the 4 mA and the 20 mA point must be separated by at least 1% of this range. Use the <b>LEFT</b> arrow key to select the first digit to be modified. Then use the <b>UP</b> and <b>LEFT</b> arrow keys to select the desired numerical value. Press <b>ENTER</b> to store the new value.</p>
<p><b>*Set 4 mA (#2)</b> <b>*Set 20 mA (#2)</b> [temp/conductivity]</p>	<p>These functions set the second 4 mA and 20 mA current loop output points for the transmitter. The output may be set to track temperature (default) or conductivity. The values stored for the 4 mA point may be higher or lower than the value stored for the 20 mA point.</p> <p>The entry value is limited to a value between 0...110° C if it is set for temperature, within the range specified in “Set Range” if the output is set to track conductivity. The 4 mA and the 20 mA point must be at least 20 units away from each other. Press <b>ENTER</b> to initiate <i>User Entry</i> mode, and the value flashes. Use the arrow keys to modify value. Press <b>ENTER</b> to store the new value.</p>
<p><b>*Set 4 mA (#3)</b> <b>*Set 20 mA (#3)</b> [temp/μS/TDS]</p>	<p><b>OPTIONAL.</b> These functions set the optional third 4 mA and 20 mA current loop output points for the analyzer. The output may be set to track temperature (default), conductivity or TDS. The values stored for the 4 mA point may be higher or lower than the value stored for the 20 mA point.</p> <p>The range is between 0...110° C if it is set for temperature, within the range specified in “Set Range” if the output is set to track conductivity, and must be within the display range established by the conductivity range if set to track TDS. The 4 mA and the 20 mA point must be at least 20 units away from each other. Press <b>ENTER</b> to initiate <i>User Entry</i> mode, and the value flashes. Use the arrow keys to modify value. Press <b>ENTER</b> to store the new value.</p>

- \*A Setpoint** This function establishes the conductivity trip point for Relay A. The entry value is limited to a value within the range specified in "Set Range". Use the **LEFT** arrow key to select the first digit to be modified. Then use the **UP** and **LEFT** arrow keys to select the desired numerical value. Press **ENTER** to store the new value.
- \*A Hysteresis** This function establishes the hysteresis, or "deadband", for Relay A. Hysteresis is most often used to control relay chattering; however, it may also be used in control schemes to separate the ON/OFF trip points of the relay. Press **ENTER** to initiate *User Entry* mode, and the value flashes. Use the arrow keys to modify value. Press **ENTER** to store the new value.
- \*A Delay** This function places an additional amount of time delay on the trip point for Relay A. This delay is in addition to the main delay setting for the controller. The entry value is limited to a value between 0...999 seconds. Press **ENTER** to initiate *User Entry* mode, and the value flashes. Use the arrow keys to modify value; range is 0...999 seconds. Press **ENTER** to store the new value.
- \*A Phasing** This function establishes the direction of the relay trip. When phase is HI, the relay operates in a direct mode. Therefore, the relay energizes and the LCD indicator illuminates when the conductivity value **exceeds** the setpoint. When the phase is LO, the relay energizes and the LCD indicator illuminates when the conductivity level drops **below** the setpoint. The failsafe setting does have an impact on this logic. The description here assumes the failsafe setting is OFF. Press **ENTER** to initiate *User Entry* mode, and the entire value flashes. Use the **UP** arrow key to modify the desired value; selections include **HI** for direct operation or **LO** for reverse operation. Press **ENTER** to store the new value. [Figure 20](#) is a visual description of a typical control relay application.

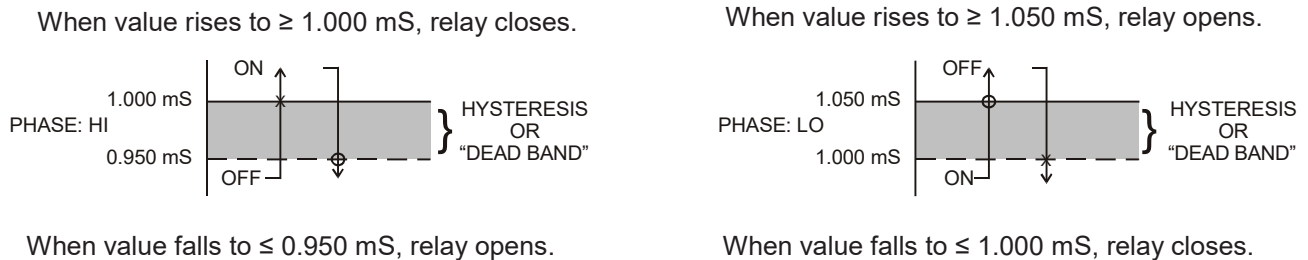

**Settings:** Setpoint: 1.000 mS  
 Hyst: 0.050  
 Delay: 000  
 Failsafe: OFF

Figure 20: Control relay example

- \*Setpnt A-HI
- \*Hyst A-HI
- \*Delay A-HI
- \*Setpnt A-LO
- \*Hyst A-LO
- \*Delay A-LO

If *Relay A* mode is set to *Alarm* mode, *AL*, then the following settings appear in the *CONFIG* menu list automatically. In this mode, two setpoints can be selected on the same relay to create an alarm band. *Phase HI* selection causes the relay to energize outside of the band, and *Phase LO* causes the relay to energize inside of the band. This feature enables one relay to be used as a control relay while the other is used as a HI-LO Alarm relay at the same time. *Setpoint A-LO* must be set lower than *Setpoint A-HI*. When *AL* mode is first selected, *Setpoint A-LO* is defaulted to 0. *Figure 21* is a visual description of a typical alarm relay application.

When value rises to  $\geq 1.000$  mS, relay closes, until value falls back to  $\leq 0.950$  mS.

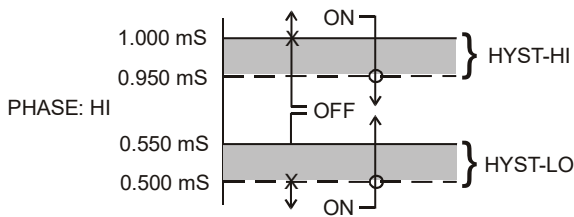

When value falls to  $\leq 0.500$  mS, relay closes, until value rises back to  $\geq 0.550$  mS.

When value falls to  $\leq 1.000$  mS, relay closes, until value rises back to  $\geq 1.050$  mS.

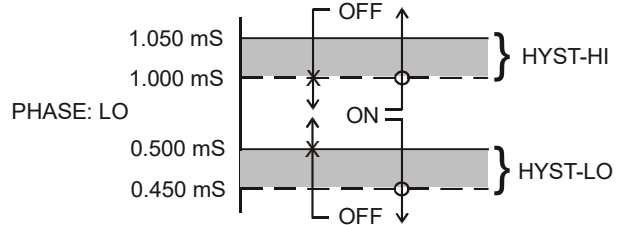

When value rises to  $\geq 0.500$  mS, relay closes, until value falls back to  $\leq 0.450$  mS.

<b>Settings:</b>	Setpoint	A-HI:	1.000 mS	Setpoint	A-LO:	0.500 mS
	Hyst	A-HI:	0.050	Hyst	A-LO:	0.050
	Delay	A-HI:	000	Delay	A-LO:	000

Figure 21: Alarm relay example

- \*B Setpoint
- \*B Hysteresis
- \*B Delay
- \*B Phasing

If *Relay B* mode is set to *CON* (see **Relay B Mode** on [page 33](#)), then Relay B functions identically to Relay A. Relay B settings appear in the *CONFIG* menu list automatically.

- C Setpoint
- C Hysteresis
- C Delay
- C Phasing

If *Relay C* mode is set to *CON* (see **Relay C Mode** on [page 33](#)), then Relay C functions identically to Relay A. Relay C settings appear in the *CONFIG* menu list automatically.

- D, E, F Setpoint
- D, E, F Hyster
- D, E, F Delay
- D, E, F Phasing

If *Relay D, E or F* mode is set to *CON* (see **Relay D, E, F Modes** on [page 33](#)), then Relays D, E and F function identically to Relay A. Relays D, E and F settings appear in the *CONFIG* menu list automatically.

## Diagnostics Menu [DIAG]

The *Diagnostics* menu contains all of the user settings that are specific to the system diagnostic functions, as well as functions that aid in troubleshooting application problems.

### Set Hold

The *Set Hold* function locks the current loop output values on the present process value, and halts operation of the PID controller. This function can be used prior to calibration, or when removing the sensor from the process to hold the output in a known state. Once *HOLD* is released, the outputs return to their normal state of following the process input. The transfer out of *HOLD* is bumpless on both analog outputs - that is, the transfer occurs in a smooth manner rather than as an abrupt change. An icon on the display indicates the *HOLD* state, and the *HOLD* state is retained even if power is cycled. Press **ENTER** to initiate *User Entry* mode, and the entire value flashes. Use the **UP** arrow key to modify the desired value, selections are **ON** for engaging the *HOLD* function and **OFF** to disengage the function. Press **ENTER** to store the new value.

**NOTE:** The *Set Hold* function holds BOTH current levels, as well as ALL relay settings.

The *Set Hold* function can also hold at an output value specified by the user. To customize the hold value, first turn the *HOLD* function on. Press the **ESC** key to go to the *DIAG* menu and scroll to *Sim Output* using the **UP** arrow key. Press **ENTER**. Follow the instructions under "*Sim Out*".

### CAUTION

**THERE IS NO TIME-OUT ON THE HOLD FEATURE. ONCE PLACED INTO HOLD MODE, RETURN TO NORMAL OPERATION MUST BE DONE MANUALLY.**

### Fault List

The *Fault List* screen is a read-only screen that allows the user to display the cause of the highest priority failure. The screen indicates the number of faults present in the system and a message detailing the highest priority fault present.

**NOTE:** Some faults can result in multiple displayed failures due to the high number of internal tests occurring. As faults are corrected, they are immediately cleared.

Faults are not stored; therefore, they are immediately removed if power is cycled. If the problem causing the faults still exists however, faults display again after power is re-applied and a period of time elapses during which the diagnostic system re-detects them. The exception to this rule is the calibration failure. When a calibration fails, no corrupt data is stored. Therefore, the system continues to function normally on the data that was present before the calibration was attempted.

After 30 minutes or if power to the transmitter is cycled, the failure for calibration clears until calibration is attempted again. If the problem still exists, the calibration failure reoccurs. Press **ENTER** to initiate view of the highest priority failure. The display automatically returns to normal after a few seconds.

### PID Timer

This function sets a timer to monitor the amount of time the PID controller remains at 0% or 100%. This function only appears if the PID controller is enabled. If the timer value is set to any number other than zero, a *FAIL* condition occurs if the PID controller remains at 0% or 100% for the timer value. If one of the relays is set to *FAIL* mode, this failure condition can be signaled by a changing relay contact.

Press **ENTER** to initiate *User Entry* mode, and the entire value flashes. Use the **UP** arrow key to modify desired value; range of value is 0...9999 seconds. Press **ENTER** to store the new value.

- Sim Out** The *Sim Out* function allows the user to simulate the chlorine level of the instrument in the user selected display range. The user enters a ppm value directly onto the screen, and the output responds as if it were actually receiving the signal from the sensor. This allows the user to check the function of attached monitoring equipment during set-up or troubleshooting. Escaping this screen returns the unit to normal operation. Press **ENTER** to initiate the *User Entry* mode, and the rightmost digit of the value flashes. Use the arrow keys to modify desired value.
- The starting display value in *SIM* mode is the last read value of the input. The output is under control of the *SIM* screen until the **ESC** key is pressed. The instrument automatically terminates the simulated output after 30 minutes and return to normal operation unless the *HOLD* function is engaged.
- NOTE:** If the *HOLD* function is engaged before the *Sim Output* function is engaged, the simulated output remains the same even when the **ESC** key is pressed. Disengage the *HOLD* function to return to normal output.
- Fail Out #1** This function enables the user to define a specified value that the main current output goes to under fault conditions. When enabled to **ON**, the output may be forced to the current value set in *Fail Val* (next item.) With the *Fail Out* setting of **ON**, and a *Fail Val* setting of 6.5 mA, any alarm condition causes the current loop output to drop outside the normal operating range to exactly 6.5 mA, indicating a system failure that requires attention.
- Press **ENTER** to initiate *User Entry* mode, and the entire value flashes. Use the **UP** arrow key to modify desired value; selections are **ON, OFF**. Press **ENTER** to store the new value.
- Fail Val #1** Sets the output failure value for *lout#1*. When *Fail Out* above is set to **ON**, this function sets value of the current loop under a *FAIL* condition. The output may be forced to any current value between 4...20 mA.
- Press **ENTER** to initiate *User Entry* mode, and the entire value flashes. Use the **UP** arrow key to modify desired value; selections are between **4 mA...20 mA**. Press **ENTER** to store the new value.
- Fail Out #2** This function sets the fail-mode of current loop output #2 under a *FAIL* condition. The settings and operation are identical to *Fail Out* for output #1.
- Fail Val #2** This function sets the value of current loop output #2 under a *FAIL* condition. The settings and operation are identical to *Fail Out* for output #1.
- \*Fail Out #3** **OPTIONAL.** This function sets the fail-mode of current loop output #3 under a *FAIL* condition. The settings and operation are identical to *Fail Out* for output #1.
- \*Fail Val #3** **OPTIONAL.** This function sets the value of current loop output #3 under a *FAIL* condition. The settings and operation are identical to *Fail Out* for output #1.
- Backlight** This function has three options: **ON** – On all the time, **OFF** – Off all the time, **AL** – Alarm (Default). This function flashes the backlight on and off whenever the “FAIL” icon is displayed.
- Failsafe** This function allows the user to set the optional system relays to a failsafe condition. In a failsafe condition, the relay logic is reversed so that the relay is electrically energized in a normal operating state. By doing this, the relay does not only change state when, for example, a chlorine limit is exceeded, but also when power is lost to the controller.
- When failsafe is selected to be **ON**, the normally-open contacts of the relay close during normal operation. In an attempt to make this configuration less confusing, the LCD icon logic is reversed with this setting, and the icon is **OFF** under this normal condition. Therefore, when the trip condition occurs, the closed N.O. contacts open (relay de-energized), and the LCD icon illuminates. In addition, a power fail would also cause the contacts to open.
- Start Delay** This function is designed to minimize control or alarm issues arising from temporary power loss. When power goes down, the monitor records the analog output values, the status of relays and PID functions. When power is restored, the analog values and relays are held at the pre-power loss values for a defined period of time. This “start delay” may be programmed for periods from 0...9.9 minutes. This function is set to 0.0 minutes by default and must be activated by the user if desired by setting a positive time value.

**Set Default**

The *Set Default* function allows the user to return the instrument back to factory default data for all user settings or for only the calibration default. It is intended to be used as a last resort troubleshooting procedure. All user settings or the calibration settings are returned to the original factory values. Hidden factory calibration data remains unchanged. Press **ENTER** to initiate *User Entry* mode and select either *ALL* or *CAL* with the **UP** arrow key.

# CALIBRATION

## Overview and Methods

Calibration of the Q46CT is required to accurately match the sensor characteristics to the monitor/analyzer. Since the output of the conductivity sensor does not degrade over time, it is typically only required that the sensor be calibrated at initial installation and then cleaned periodically to maintain proper system accuracy.

It is important for the user to establish a periodic cleaning and calibration-check schedule for sensor maintenance to maintain high system accuracy. Since the conductivity of a solution is greatly affected by temperature, proper settings for thermal compensation are critical for accurate operation. Before calibrating the instrument for the very first time, it is important to select the proper operating parameters in the *Configuration* menus for temperature compensation methods.

When using conductivity calibration standards for a wet calibration, take care not to inadvertently contaminate the reference solution; always thoroughly clean the sensor, rinse off in tap water and then finish rinsing in pure or de-ionized water.

**NOTE:** Calibration solutions less than 200  $\mu\text{S}$  or greater than 100  $\text{mS}$  can be very unstable. Moving the sensor back and forth between different value conductivity reference solutions can quickly contaminate the solutions and render them inaccurate.

### 1-Point Calibration Explained

The 1-point calibration method is generally known as the “grab sample” calibration method. In the 1-point calibration method, the sensor may be removed from the application and placed into a reference solution. It may also be left in the measurement process and calibrated by reference. The 1-point calibration adjusts the sensor slope to match the exact calibration point. Readings beyond that point are then extrapolated from the determined slope of the calibration line. Since the sensor slope does not degrade over time, frequent re-calibration is unnecessary. Calibration accuracy can be optimized by calibrating with a reference solution which is close to the values typically measured.

### Zero Cal Explained

The sensor offset must be set for the system only on initial sensor installation or when the cable length has been altered. The Zero Cal method establishes all of the sensor offset points for the instrument’s 6 ranges of operation.

## Performing Sensor Zero Calibration

The sensor offset **MUST** be set for the system on initial sensor installation or when the cable length has been altered. However, it can easily be adjusted at any time by re-calibrating the sensor in air. The sensor zero-calibration generally has little effect in measurements above about 50  $\text{mS}$ , but it can have a significant effect in measurements below about 1  $\text{mS}$ . If the sensor zero cal is to be performed, it must be done **BEFORE** the 1-point reference calibration.

To begin the sensor zero cal, verify that the sensor is connected, clean and dry. It should be placed in the air with the electrodes at least 1 ft away from any nearby objects. Holding it is not recommended – place on table or just hang.

### Procedure

1. Remove sensor from process and clean thoroughly. Dry sensor and position on table or hang in air (in air is best). If on table, let end of sensor hang over the edge of table.
2. Scroll to the *CAL* menu section using the **MENU** key and press **ENTER** or the **UP** arrow key. Scroll to the menu *Zero Cal*.
3. Press the **ENTER** key. The screen prompts the user to position the sensor in air.
4. Press the **ENTER** key. The screen automatically scrolls through all ranges and establish and store the proper zero points.

## Performing a 1-Point Calibration

This calibration method is intended to be used as an online calibration method or a wet-cal with reference solutions. During calibration, the system displays the current conductivity reading, and the user can manually enter a reference value from a reference solution bottle or a comparative reference instrument.

For wet calibrations, the user may use pre-made calibration references (also available from Badger Meter) or a NaCl solution may be made using pure, dried NaCl crystals and one liter of high purity, de-ionized, CO<sub>2</sub>-free water as mixed in the table shown in “[NaCl Reference Solution for Calibration \(25° C\)](#)”. All table data is at 25° C, therefore, the sensor must be at this temperature to calibrate properly using the table data. If another reference calibration solution is being used, be sure to note temperature of reference solution before calibration. Since the sensor must ideally be at the specified temperature, wet calibrations can be difficult to perform accurately.

#### [NaCl Reference Solution for Calibration \(25° C\)](#)

$\mu\text{S/cm}$	NaCl (gm)
100	0.05
200	0.10
500	0.25
1000	0.50
2000	1.01
3000	1.53
4000	2.06
5000	2.61
8000	4.34
10000	5.56
20000	11.59

During the 1-point calibration, the system automatically picks the correct range for the calibration reference if the Q46CT is in the *AUTO* range. If the Q46CT is in a normal display mode, the user must be careful to calibrate with a solution that falls into the manual range selected. If the calibration solution is outside the manual range, an error results.

#### Procedure

1. If a zero calibration on the sensor is also to be performed, that must be done **FIRST**. The zero calibration process can have an impact on the result of the 1-point calibration. So if a zero cal is required, do that procedure and return here.
2. Determine whether the calibration is done online or with the sensor removed and placed into a reference solution. If the sensor is removed from the application, rinse and clean.
3. If the sensor has been removed and placed into a solution, allow the sensor to temperature equilibrate with the solution as much as possible. With the sensor coming from an application that differs greatly in temperature, the user may have to wait as much as 20 minutes. If the sensor is online, the user may want to set the output *HOLD* feature prior to calibration to lock out any output fluctuations.
4. Scroll to the *CAL* menu section using the **MENU** key and press **ENTER** or the **UP** arrow key. Scroll until *Cal Cond* displays. Press **ENTER**.
5. The screen prompts the user to place the sensor into the reference solution (ideally this has already been done to achieve temperature equilibrium). Once sensor is ready, press **ENTER**.
6. The system now begins acquiring data for the calibration value. As data is gathered, the units for conductivity and temperature may flash. Flashing units indicate that this parameter is unstable. The calibration data point acquisition stops only when the data remains stable for a pre-determined amount of time. This can be overridden by pressing **ENTER**. If the data remains unstable for 10 minutes, the calibration fails and the message “Cal Unstable” displays.
7. The screen displays the last measured conductivity value and a message displays prompting the user for the reference value. The user must then modify the screen value with the arrow keys and press **ENTER**. The system then performs the proper checks.
8. If accepted, the screen displays the message “PASS” with the slope value, then it returns to the main measurement display. If the calibration fails, a message indicating the cause of the failure displays and the *FAIL* icon turns on.

## Temperature Calibration

The temperature input is factory calibrated for the highest accuracy. Temperature calibration is not recommended; however, it is provided for applications in which very long cable lengths are needed. For example, at 50 ft, readings may be off  $\pm 0.2^\circ\text{C}$ .

The temperature calibration sequence is essentially a 1-point offset calibration that allows adjustments of approximately  $\pm 5^\circ\text{C}$ .

The sensor temperature may be calibrated on line, or the sensor can be removed from the process and placed into a known solution temperature reference. In any case, it is critical that the sensor be allowed to reach temperature equilibrium with the solution in order to provide the highest accuracy. When moving the sensor between widely different temperature conditions, it may be necessary to allow as much as one hour before the calibration sequence is initiated. If the sensor is online, the user may want to set the output *HOLD* (see "*Diagnostics Menu [DIAG]*" on page 37) feature prior to calibration to lock out any output fluctuations.

### Procedure

1. Scroll to the *CAL* menu section using the **MENU** key and press **ENTER** or the **UP** arrow key.
2. Press the **UP** arrow key until Cal Temp is displayed.
3. Press the **ENTER** key. The message "Place sensors in solution then press ENTER" displays. Move the sensor into the calibration reference (if it hasn't been moved already) and wait for temperature equilibrium to be achieved. Press **ENTER** to begin the calibration sequence.
4. The calibration data gathering process begins. The message "Wait" flashes as data is accumulated and analyzed. The **°C** or **°F** symbol may flash periodically if the reading is too unstable.
5. The message "Adjust temp value then press ENTER" displays, and the rightmost digit begins to flash, indicating that the value can be modified. Using the **UP** and **LEFT** arrow keys, modify the value to the known ref solution temperature. Adjustments up to  $\pm 5^\circ\text{C}$  from the factory calibrated temperature are allowed. Press **ENTER**.
6. Once completed, the display indicates *PASS* or *FAIL*. If the unit fails, the temperature adjustment may be out of range, the sensor may not have achieved complete temperature equilibrium or there may be a problem with the temperature element. In the event of calibration failure, it is recommended to attempt the calibration again immediately.

## PID CONTROLLER DETAILS

### PID Description

PID control, like many other control schemes, is used in chemical control to improve the efficiency of chemical addition or control. By properly tuning the control loop that controls chemical addition, only the amount of chemical that is truly required is added to the system, saving money. The savings can be substantial when compared to a system that may be simply adding chemical at a constant rate to maintain some minimal addition under even the worst case conditions. The PID output controller is highly advantageous over simple control schemes that just use direct (proportional only) 4...20 mA output connections for control, since the PID controller can automatically adjust the "rate" of recovery based on the error between the setpoint and the measured value – which can be a substantial efficiency improvement.

The PID controller is basically designed to provide a "servo" action on the 4...20 mA output to control a process. If the user requires that a measured process stay as close as possible to a specific setpoint value, the controller output changes from 0...100% in an effort to keep the process at the setpoint. To affect this control, the controller must be used with properly selected control elements (valves or proper chemicals, for example) that enable the controller to add or subtract chemical rapidly enough. This is not only specific to pumps and valves, but also to line sizes, delays in the system, for example.

This section is included to give a brief description of tuning details for the PID controller, and is not intended to be an exhaustive analysis of the complexities of PID loop tuning. Numerous sources are available for specialized methods of tuning that are appropriate for a specific application.

### PID Algorithm

As most users of PID controllers realize, the terminology for the actual algorithm terms and even the algorithms themselves can vary between different manufacturers. This is important to recognize as early as possible, since just plugging in similar values from one controller into another can result in dramatically different results. There are various basic forms of PID algorithms that are commonly seen. The implementation here is the most common version (the ISA algorithm, commonly referred to as the "ideal" algorithm).

### PID Equation

$$output = P \left[ e(t) + \frac{1}{I} \int e(t) dt + D \frac{de(t)}{dt} \right]$$

Where:

output =	controller output
P =	proportional gain
I =	integral gain
D =	derivative gain
t =	time
e(t) =	controller error (e=measured variable – setpoint)

The most notable feature of the algorithm is the fact the proportional gain term affects all components directly (unlike some other algorithms - like the "series" form). If a pre-existing controller uses the same form of the algorithm shown above, it is likely similar settings can be made if the units on the settings are exactly the same. Be careful of this, as many times the units are the reciprocals of each other (for example, reps-per-min or sec-per-rep).

PID stands for "proportional, integral, derivative." These terms describe the three elements of the complete controller action, and each contributes a specific reaction in the control process. The PID controller is designed to be primarily used in a "closed-loop" control scheme, where the output of the controller directly affects the input through some control device, such as a pump or valve, for example.

Although the three components of the PID are described in the setting area [“Control Menu” on page 34](#), here are more general descriptions of what each of the PID elements contribute to the overall action of the controller.

- P** Proportional gain. With no *I* or *D* contribution, the controller output is simply a factor of the proportional gain multiplied by the input error (difference between the measured input and the controller setpoint.) Because a typical chemical control loop cannot react instantaneously to a correction signal, proportional gain is typically not efficient by itself – it must be combined with some integral action to be useful. Set the *P* term to a number between 2...4 to start. Higher numbers cause the controller action to be quicker.
- I** Integral gain. Integral gain is what allows the controller to eventually drive the input error to zero, providing accuracy to the control loop. It must be used to affect the accuracy in the servo action of the controller. Like proportional gain, increasing integral gain results in the control action happening quicker. Set the *I* term to a number between 3...5 to start (1...2 more than *P*). Like proportional gain, increasing the integral term causes the controller action to be quicker.
- D** Derivative gain. The addition of derivative control can be problematic in many applications because it greatly contributes to oscillatory behavior. In inherently slow chemical control processes, differential control is generally added in very small amounts to suppress erratic actions in the process that are non-continuous, such as pumps and valves clicking on and off. However, as a starting point for chemical process control, its best to leave the *D* term set to 0.

Based on these descriptions, the focus on tuning for chemical applications really only involves adjustment of *P* and *I* in most cases. However, increasing both increases the response of the controller. The difference is in the time of recovery. Although combinations of high *P*s and low *I*s appear to operate the same as combinations of low *P*s and high *I*s, there is a difference in rate of recovery and stability. Because of the way the algorithm is structured, large *P*s can have a larger impact to instability, because the proportional gain term impacts all the other terms directly. Therefore, keep proportional gain lower to start and increase integral gain to achieve the effect required.

Many of the classical tuning techniques have the user start with all values at 0, and then increase the *P* term until oscillations occur. The *P* value is then reduced to 1/2 of the oscillatory value, and the *I* term is increased to give the desired response. This can be done with the Q46CT controller, with the exception that the *I* term should start no lower than 1.0.

If it appears that even large amounts of integral gain (>20) do not appreciably increase the desired response, drop *I* back to about 1.0, and increase *P* by 1.00 and start increasing *I* again. In most chemical control schemes, *I* is approximately 3 times the value of *P*.

## Classical PID Tuning

Unlike many high speed position applications where PID loops are commonly used, the chemical feed application employed by this instrument does not require intense mathematical exercise to determine tuning parameters for the PID. In fact, the risk of instability is far greater with overly tuned PID control schemes. In addition, many of the classical mathematical exercises can be damaging or wasteful in the use of chemicals when the process is bumped with large amounts of input error to seek a response curve. Because of this, the general adjustment guidelines described in [“PID Algorithm” on page 43](#) are sufficient for almost all application tuning for this instrument. Beyond this, many sources are available for classical tuning methods.

---

## Manual PID Override Control

The Q46 *PID Output* function allows the user to take manual control of the PID control signal. This is often useful when starting up a control loop or in the event that you wish to bump the system manually to measure system response time.

To access the manual PID control, you must be in the *MEASURE* mode of operation and you must have the PID output displayed on the lower line. This line indicates “XX.X% XX.X mA” with the X values simply indicating the current values. With this display on the screen, press and hold the **ENTER** key for about 5 seconds. A small “m” shows up between the % value and the mA value. This indicates you are now in *Manual* mode.

Once in manual, you may increase the PID output by pressing the **UP** arrow key or you may decrease the output by pressing the **LEFT** arrow key. This allows you to drive the PID output to any desired setting.

To revert to normal PID control, press and hold the **ENTER** key again until the “m” indicator disappears.

## Common PID Pitfalls

The most common problem occurring in PID control applications involves the false belief that proper settings on only the PID controller can balance any process to an efficient level.

Close-loop control can only be effective if all elements in the loop are properly selected for the application and the process behavior is properly understood. Luckily, the nature of simple chemical control processes are generally slow in nature. Therefore, even a de-tuned controller (one that responds somewhat slow) can still provide substantial improvements to setpoint control. In fact, damaging oscillatory behavior is far more likely in tightly tuned controllers where the user attempted to increase response too much.

When deciding on a PID control scheme, it is important to initially review all elements of the process. Sticking valves, undersized pumps or delays in reaction times associated with chemical addition can have a dramatic effect on the stability of the control loop. When controlling a chemical mix or reaction, the sensor should be placed in a location that ensures proper mixing or reaction time has occurred.

The easiest processes to control with closed-loop schemes are generally linear, and symmetrical, in nature. For example, controlling level in tank where the opening of valve for a fixed period of time corresponds linearly to the amount that flows into a tank. Chemical control processes can be more problematic when the nature of the setpoint value is nonlinear relative to the input of chemical added. For example, pH control of a process may appear linear only in a certain range of operation and become highly exponential at the extreme ranges of the measuring scale. In addition, if a chemical process is not symmetrical, that means it responds differentially to the addition and subtraction of chemical. It is important in these applications to study steady-state impact as well as step-change impact to process changes. In other words, once the process has apparently been tuned under normal operating conditions, the user should attempt to force a dramatic change to the input to study how the output reacts. If this is difficult to do with the actual process input (the recommended method), the user can place the control in manual at an extreme control point such as 5% or 95%, and release it in manual. The recovery should not be overly oscillatory. If so, the loop needs to be de-tuned to deal with that condition (reduce *P* and/or *I*).

## SYSTEM MAINTENANCE

### System Checks

1. If the *FAIL* icon is flashing on the display, check the *Fault List* to determine the cause of the failure. To access the *Fault List*, press the **MENU/ESC** key until the *DIAG* menu appears. Then press the **UP** arrow key until the *Fault List* appears. Press the **ENTER** key to access the *Fault List*, and the highest priority fault message displays. For a list of all messages and possible causes/solutions, see "*Display Messages*" on page 48.
2. In **ALL** environments, connect an earth ground jumper to earth terminal connection on transmitter.
3. Perform a 1-point calibration prior to sensor installation.
4. Check sensor cable color to terminal strip markings.
5. For highly unstable behavior, remove sensor from the process and measure the process solution in a plastic beaker. If the reading now stabilizes, place wire in beaker solution and actual process solution to determine if a ground loop exists.
6. If the instrument 4...20 mA output is connected into other control systems, disconnect output loop from system load and run through a handheld DMM to monitor current. Verify that the system operates correctly in this mode first.

### Instrument Checks

1. Remove sensor completely and connect 1100 Ohms from the GREEN to BLACK (green bundle) on the analyzer input leads. The temperature reading should display approximately 25° C and the conductivity reading should display approximately 0.0  $\mu$ S.
2. Reconnect the sensor and leave dry in air. With a DMM, measure the AC voltage between RED and BLACK sensor leads. The DMM should read between 100 mVrms...300 mVrms @ about 10 kHz. The display should show some value close to 0  $\mu$ S if the sensor has been properly zero calibrated.

## Sensor Tests

Toroidal sensors can be tested with a digital voltmeter (DVM) to determine if a major sensor problem exists. Follow the steps below to verify sensor integrity:

1. Disconnect the nine sensor wires from the terminal strip on the transmitter. Check sensor plastic covering for any mechanical damage to plastic covering.
2. Connect a DVM between the RED and BLACK wires in the red jacket pair. With the DVM set to measure resistance, you should measure between 0.4...2.0 Ohms.
3. Connect a DVM between the WHITE and BLACK wires in the white jacket pair. With the DVM set to measure resistance, you should measure between 0.4...2.0 Ohms.
4. Connect a DVM between the WHITE wire from the white jacket pair, and the RED wire from the red jacket pair. With the DVM set to measure resistance, you should measure an open circuit.
5. Connect a DVM between the GREEN and BLACK wires in the green jacket pair. These are the RTD leads, and you should find a resistance value that depends on the temperature. The table below lists the resistance values for various temperatures:

Temperature	Resistance
0° C	1000 $\Omega$
5° C	1019 $\Omega$
10° C	1039 $\Omega$
15° C	1058 $\Omega$
20° C	1078 $\Omega$
25° C	1097 $\Omega$
30° C	1117 $\Omega$
35° C	1136 $\Omega$
40° C	1155 $\Omega$
45° C	1175 $\Omega$
50° C	1194 $\Omega$

## Display Messages

The Q46 Series instruments provide a number of diagnostic messages which indicate problems during normal operation and calibration. These messages appear as prompts on the secondary line of the display or as items on the *Fault List*.

The following messages appear as prompts:

Message	Description	Possible Correction
Cal Unstable	Calibration problem, data too unstable to calibrate.	Clean sensor, get fresh cal solutions, allow temperature and conductivity readings to fully stabilize. Do not handle sensor or cable during calibration.
Slope HIGH	Sensor slope from calibration is greater than 400%.	Get fresh cal solutions, allow temperature and conductivity readings to fully stabilize, check for correct buffer values.
Slope LOW	Sensor slope from calibration is less than 20%.	Clean sensor, get fresh cal solutions, allow temperature and conductivity readings to fully stabilize, check for correct buffer values.
Offset HIGH	Sensor offset from calibration is too high.	Clean sensor, get fresh cal solutions, allow temperature and conductivity readings to fully stabilize, check for correct solution values.
Out of Range	Input value is outside selected range of the specific list item being configured.	Check manual for limits of the function to be configured.
Locked!	Transmitter security setting is locked.	Enter security code to allow modifications to settings.
Unlocked!	Transmitter security has just been unlocked.	Displayed just after security code has been entered.
TC-F25 lock!	The TC won't calibrate because there is something wrong with the connection to the temperature element in the sensor.	Perform sensor tests and instrument tests to confirm operation of TC in sensor. Check all connections between sensor and instrument.

The following messages appear as items on the *Fault List*:

Message	Description	Possible Correction
Sensor High	The raw signal from the sensor is too high.	Check wiring connections to sensor.
Sensor Low	The raw signal from the sensor is too low.	Check wiring connections to sensor.
Cond Too High	The conductivity reading is > 2000 mS.	The conductivity reading is over operating range limits. Move to a higher range or select <i>Auto</i> from main display in <i>CONFIG</i> menu.
Temp High	The temperature reading is > 210° C.	The temperature reading is over operating limits. Check wiring and expected temp level. Perform RTD test as described in sensor manual. Recalibrate sensor temperature element if necessary.
Temp Low	The temperature reading is < -10° C.	The temperature reading is under operating limits. Check wiring and expected temp level. Perform RTD test as described in sensor manual. Recalibrate sensor temperature element if necessary.
TC Error	TC may be open or shorted.	Check sensor wiring and perform RTD test as described in sensor manual.
Cond Cal Fail	Failure of conductivity calibration.	Clean sensor, get fresh cal solutions and redo calibration. Verify conductivity value of application or reference solutions. Perform sensor tests as described in sensor manual. Replace sensor if still failure.
EEprom Fail	Internal non-volatile memory failure.	System failure, consult factory.
Chcksum Fail	Internal software storage error.	System failure, consult factory.
Display Fail	Internal display driver fail.	System failure, consult factory.
Range Cal Fail	Failure of factory temperature calibration.	Consult factory.

## SPARE PARTS

Part No.	Description
03-0396	Q46CT Front Lid Assembly
*	Q46CT Monitor, 100...240V AC
*	Q46CT Monitor, 12...24V DC
*	Q46CT Monitor, 100...240V AC with Profibus
*	Q46CT Monitor, 12...24V DC with Profibus
03-0407	Q46 P/S Assy, 100...240V AC
03-0408	Q46 P/S Assy, 100...240V AC with 3rd 4...20 mA Output
03-0409	Q46 P/S Assy, 100...240V AC with 3 Relay Exp. Board
03-0410	Q46 P/S Assy, 12...24V DC
03-0411	Q46 P/S Assy, 12...24V DC with 3rd 4...20 mA Output
03-0412	Q46 P/S Assy, 12...24V DC with 3 Relay Exp. Board
38-0072	Terminal Block Plug, 3 Position (Relays)
38-0073	Terminal Block Plug, 4 Position (Outputs)
38-0074	Terminal Block Plug, 3 Position (Ground)
38-0081	Terminal Block Plug, 3 Position (Power)
38-0084	Terminal Block Plug, 3 Position (Power) – V DC version **
23-0029	Fuse, 630 mA, 250V, TR-5 (for AC and DC Analyzers)
07-0100	Junction Box
63-0099	Toroidal Sensor, Noryl, 20 ft Cable
31-0068	Sensor Interconnect Cable
09-0046	Conductivity Standard – 84 microSiemens, 500 mL
09-0047	Conductivity Standard – 447 microSiemens, 500 mL
09-0048	Conductivity Standard – 1,500 microSiemens, 500 mL
09-0049	Conductivity Standard – 8,974 microSiemens, 500 mL
09-0050	Conductivity Standard – 80,000 microSiemens, 500 mL

\* Please consult factory for electronic assemblies part numbers.

\*\* Prior to Dec 2018, V DC (power) Terminal Block used the (38-0081).

**Lock/Unlock Code: 1467**

**INTENTIONAL BLANK PAGE**

