



INSTALLATION, OPERATION & MAINTENANCE MANUAL

MODEL EK



ORBINOX SPAIN Pol.Ind. s/n-20270 ANOETA. Tel:+34 943 698030 Fax:+34 943 653066 e-mail:orbinox@orbinox.com

ORBINOX CANADA, ORBINOX USA, ORBINOX BRAZIL, ORBINOX SPAIN, ORBINOX UK, ORBINOX FRANCE,
ORBINOX GERMANY, ORBINOX INDIA, ORBINOX CHINA, ORBINOX S.E.A.

www.orbinox.com

INDEX

	<u>Page</u>
0. - Description	2
1. - Handling	2
2. - Installation	3
3. - Actuators	6
4. - Maintenance	6
4.1. - Gland packing replacement	7
4.2. - Seal replacement	8
4.3. - Lubrication	9
5. - Storage	10
6. - Parts list & drawing	11

0.- DESCRIPTION

The EK model knife gate is a uni-directional wafer valve designed for general industrial service applications. The design of the body and seat assures non-clogging shut-off with suspended solids.

The EK valve complies with the following European directives:

- **DIR 98/37/EC (machines)**
- **DIR 97/23/EC (PED)** Fluid: Group 1 (b), 2 (Cat. I, mod.A)

It may also comply with the directive:

- **DIR 94/9/EC (Explosive Atmospheres)**



The EK valve may comply with the directive regarding equipment and protective systems for their use in explosive atmospheres. In these cases, the logotype  shall appear on the identification label of the valve. This label shows the exact classification of the zone where the valve can be used. The user will be liable for its use in any other zone.

This directive only applies in the following atmospheric conditions:

$$0,8 \text{ bar} \leq P \leq 1,2 \text{ bar}$$

$$-20^{\circ}\text{C} < T < 60^{\circ}\text{C}$$

Any increase in temperature due to frictional warmth is negligible, since the relative speed of the moving parts is extremely low.

The risk analysis associated to this directive does not take into account the fluid that goes through the valve, even when such fluid produces an explosive atmosphere. The user must take into account the risks that the fluid generates, such as:

- heating of the valve surface.
- generation of electrostatic charges caused by displacement of the fluid.
- shock waves caused by the installation (water hammer), internal crashes generated by the pellets or the risks due to foreign bodies susceptible of being present in the installation.

1.- HANDLING

When handling an Orbinox valve please pay attention to the following points:



- **Do NOT attach lifting gear to the valve actuators or gate guards.**
They are not designed to bear the weight, and could easily be damaged.
- **Do NOT lift the valve by the valve bore.**
This can cause damage to the seating surfaces and seals.
- Check that selected lifting gear is rated to carry the weight of the valve.
- The valve can be handled using eyebolts, soft straps or slings.

- Eyebolts: make sure the eyebolts have the same thread as the boltholes and they are all well secured. Ideally when using lifting gear to move an Orbinox valve, it should be supported by two or more eyebolts screwed into the tapped fixing holes in the valve body.
- Soft straps: with the valve in the closed position, the straps should be placed between the gland area and the bore such that the valve is balanced.

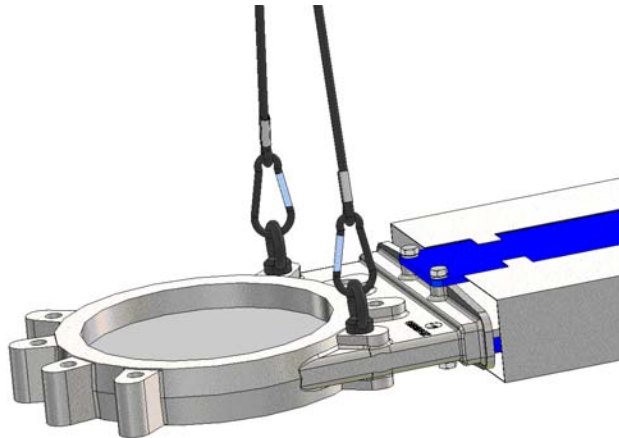

Fig. 1 Handling with eyebolts

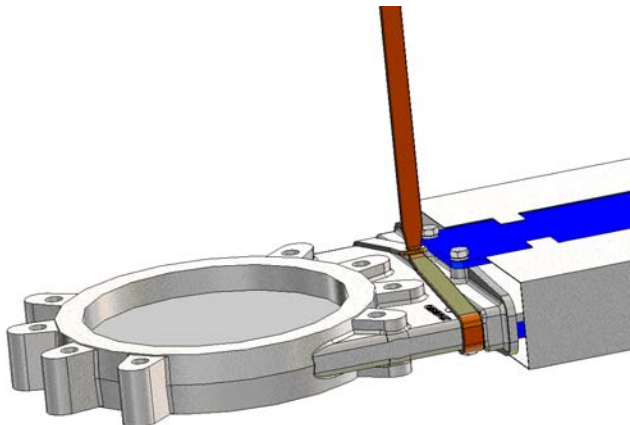

Fig. 2 Handling with soft straps

2.- INSTALLATION

To avoid personal injury or damage to property from the release of process fluid:



- Those in charge of handling and maintenance of the valve must be qualified and trained in valve operations.
- Use appropriate personal protection equipment (gloves, safety shoes, etc).
- Shut off all operating lines to the valve and place a warning sign.
- Isolate the valve completely from the process.
- Release process pressure.
- Drain the process fluid from the valve.
- According to **EN 13463-1 (15)**, during installation and maintenance operations, use hand tools (**non electric**) with Working Allowance.

Before installation, inspect the valve body and components for any damage that may have occurred during shipping or storage. Make sure the internal cavities within the valve body are clean. Inspect the pipeline and mating flanges, making sure the pipe is free of foreign material and that the flanges are clean.

The valve is unidirectional. It should be installed with pressure exerted against the seat. The words "SEAT SIDE" are marked on the valve body to indicate the position of the valve seat. Installation and the correct orientation with respect to the direction of the flow is the responsibility of the user.

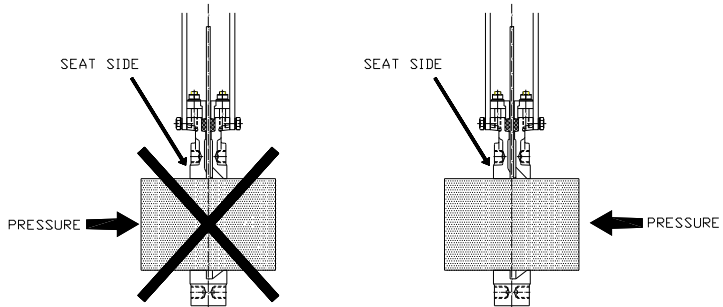

It should be noted that the direction of flow and differential pressure, do not always coincide.

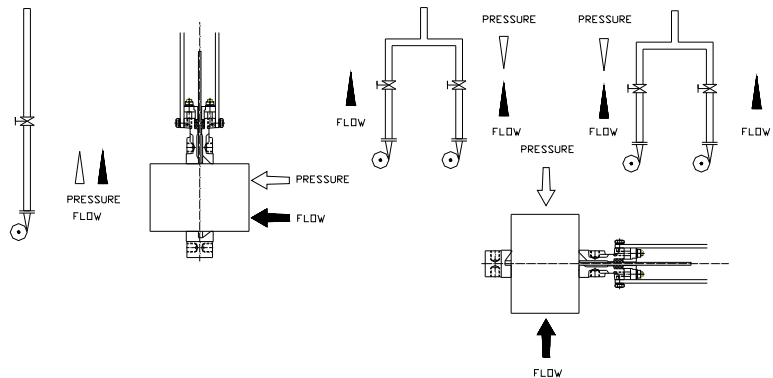

Special care should be taken to maintain the correct distance between the flanges and to ensure that they are parallel to the valve body. Incorrect alignment of the valve can cause deformations, which can lead to difficulties in operation.

The following table gives the maximum torque values for the valve fixing bolts. Also shown is the maximum depth (T) allowed for the tapped blind boltholes drilled into the valve body.

DN	50	65	80	100	125	150	200	250	300	350	400	450	500	600
T (mm)	10	10	10	10	10	14	14	18	18	22	24	24	24	24
Kg.m	6	6	6	6	7	7	7	11	11	15	15	19	19	23

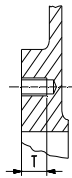

The valve can be mounted in any position with regard to the pipe. However, it is advisable to place it vertically in horizontal pipeline (A) if the installation allows it. (Please consult the technical department at Orbinox).

With larger diameters (> 300 mm), heavy actuators (pneumatic, electric, etc.), or with the valve installed horizontally (B) or at an angle (C) on a horizontal pipeline, the installation will require the construction of suitable supports. (See the following diagram and consult the technical department at Orbinox).

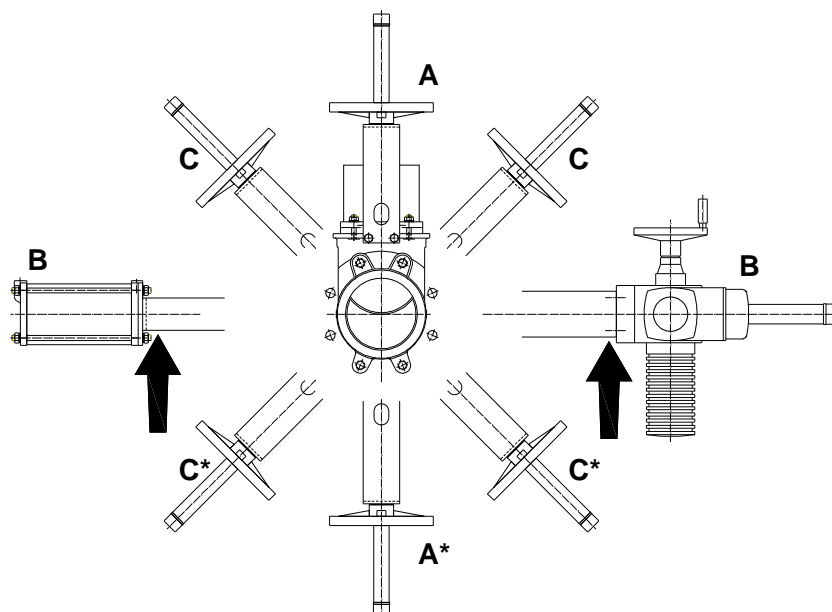

** For these positions please consult Orbinox.*

In vertical pipelines, the construction of suitable supports is always required (for further information please consult the technical department at Orbinox).

Once the valve is installed, test that the flanges have been fastened correctly and that all electrical and/or pneumatic connections have been properly made.

These instructions must be observed when installing an Orbinox knife gate valve in an ATEX zone:



- Make sure the valve is ATEX marked according to the requested zone and it includes all anti-static devices.
- Check continuity between the body of the valve and the pipe (test in accordance with EN 12266-2 Standard, annex B, points B.2.2.2. and B.2.3.1).
- This check must be done every time the valve has been removed from the line, serviced, and put back to the line.



The operation of automated valves is limited only with fitted gate covers.

First, operate the valve with no flow in the pipeline. Then test operation and valve seal with flow. It should be noted that the packing material might settle in shipping/storage, which can cause minor leakage. This can be remedied by tightening the gland follower (7) during installation. The nuts shall be tightened gradually and crosswise until the leakage stops (see the next figure). Check that there is no metal contact between the gland follower (7) and the gate (2).

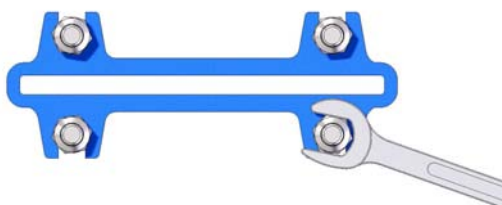

If the glandfollower nuts are pulled to hard, the force needed to operate the valve will increase, the valve function will be affected and the box packing lifetime will be shortened.

The table below shows the maximum torque value for tightening the glandfollower nuts.

DN	Torque (N.m)
50 - 100	20
125 - 200	30
250 - 1000	35

Once performance has been tested, the valve can be put into operation.

3.- ACTUATORS

3.1. - Handwheel

To open the valve, turn the handwheel (14) anticlockwise. To close, turn the handwheel clockwise.

3.2. - Lever

To operate the valve with this device, first loosen the locking clamp located on the top of the yoke (10). Then either open or close the valve by moving the lever in the desired direction. Finally, fix the position of the lever with the locking clamp.

3.3. - Pneumatic

Valves are usually supplied with a double acting pneumatic actuator although, upon request, we can supply single-acting actuators. In either case the feed pressure can vary between 3,5 and 10 Kg/cm². However, the size of the actuator for each valve has been designed for a feed pressure of 6 Kg/cm².

It is essential for a good maintenance of the cylinder that air should be well dried, filtered and lubricated.

It is recommended to actuate the cylinder 3-4 times before the start up, once it is installed in the pipeline.

3.4. - Electric actuator

Depending on the type or make of the electric actuator, specific instructions (i.e. a manufacturer's manual) will be supplied.



- Allowed actuators for ATEX zones: Hand wheel, Chain Wheel, Bevel Gear, Lever, Pneumatic Actuator (double acting **ONLY**) and Electric Motor
- Make sure these actuators are ATEX marked according to the requested zone.
- Maximum travel speed of the gate must equal or below 0,05 m/s

4.- MAINTENANCE

The valve must not undergo any modifications without a previous agreement with ORBINOX.

ORBINOX shall not be liable for any damages that may arise due to the use of non original parts or components



To avoid personal injury or damage to property from the release of process fluid:

- Those in charge of handling and maintenance of the valve must be qualified and trained in valve operations.

- Use appropriate personal protection equipment (gloves, safety shoes, etc).
- Shut off all operating lines to the valve and place a warning sign.
- Isolate the valve completely from the process.
- Release process pressure.
- Drain the process fluid from the valve.
- According to **EN 13463-1 (15)**, during installation and maintenance operations, use hand tools (**non electric**) with Working Allowance.

The only maintenance required is to change the gland packing (6) or the seal (3) if the valve is a resilient seated type.

The life of these elements will depend on the working conditions of the valve such as: pressure, temperature, abrasion, chemical action, number of operations, etc.

4.1. - Replacement of the gland packing (6):

- 1) Depressurise the circuit and place the valve in close position.
- 2) Remove the gate guards (for automatically actuated valves only).
- 3) - Non rising stem. Photo 1: Release the stem nut (8) from the gate (2).
- Rising stem valves. Photo 2: Release the spindle or stem (9) from the gate (2).

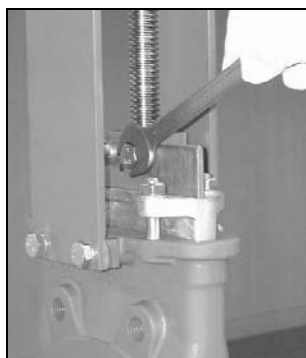

Photo 1

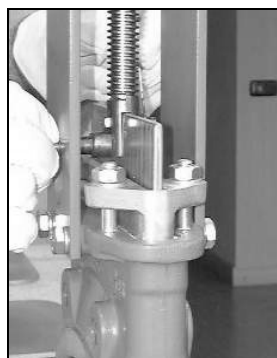

Photo 2

- 4) Loosen the screws of the yoke (10) and remove it (without loosing the actuator).
- 5) Loosen the nuts of the gland follower (7) and remove it. (Photo 3).
- 6) Remove the old packing rings (6) and clean the stuffing box.
- 7) Insert the new packing rings (6), making sure that the ring joints alternate (the first on one side of the gate, the next on the other and so on). (Photo 4).
- 8) Once the necessary packing rings (6) have been inserted, proceed with a steady initial tightening of the gland follower (7). (Photo 3).
- 9) Place the yoke (10) (with the actuator) and screw it.
- 10) Fix the stem nut (8) to the gate. (Non rising stem. Photo 1) or fix the stem (9) to the gate (2) (Rising stem valves. Photo 2).
- 11) Remount the gate guards (for automatically actuated valves only).
- 12) Carry out some operations with a loaded circuit and then re-tighten the gland follower (7) to prevent leakage.



Photo 3

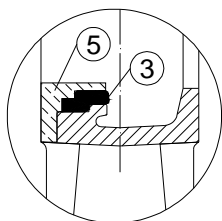

Photo 4

4.2. - Replacement of the seal (3) (only applicable to resilient seated valves):

- 1) Remove the valve from the pipeline.
- 2) Remove the gate guards (for automatically actuated valves only).
- 3) Release the stem nut (8) from the gate (2). (Non rising stem.Photo 1) or release the spindle or stem (6) from the gate (2). (Rising stem valves.Photo 2).
- 4) Loosen the screws of the yoke (10) and remove it (without loosing the actuator).
- 5) Loosen the nuts of the gland follower (7) and remove it.(Photo 3)
- 6) Remove the old packing (6) and the gate (2) and clean the stuffing box.
- 7) Remove the seal retainer ring (5) which supports the seal (3).
- 8) Remove the worn seal (3) and clean the seal housing.
- 9) Insert the new seal (3) in the retainer ring (5).
 If the valve has PTFE seal (3): first, place an O-ring (4) in the retainer ring (5) and later place the PTFE seal (3). (see the following detail).

EPDM / NITRILE



PTFE

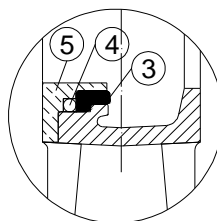

- 10) Insert the seal retainer ring (5) and the seal (3) altogether by hammering gently around the edge.
- 11) Remount the gate (2).
- 12) Once the necessary packing rings (6) have been inserted, proceed with a steady initial tightening of the gland follower (7). (Photo 3) following the steps of point 4.1.

4.3. - Lubrication:

Lubricate the stem every 30 days with a calcium-based grease with the following characteristics: highly water resistant, low ash content, and excellent adherence.



Special requirements for ATEX valves:

- The maintenance personnel must be made fully aware of the risks of explosion, and it is advisable that they receive specific training regarding ATEX.
- Periodicity of check and evaluation of graphite packing status and valve electrical conductivity must be determined by end user according to valve working conditions. In any case, once the valve is put into operation, the packing area must be revised after the valve has been stroked 100 times or after 3 months of operation, whatever happens first. After this preliminary check, new checking periods must be determined by end user based on the results of this first check.
- Clean the valve periodically to prevent dust accumulation. Do not sweep or dump the dust. Always use a vacuum cleaner system
- Dead in service is not allowed.
- Do not apply any new coating to the valve. Should it require new coating, please contact our closest representative.
- Allowed seals: EPDM, VITON, NITRILE, GRAPHITE and METAL (no seal)
- Allowed packing: ST and GRAPHITE packing
- Any other materials but those above are not allowed to be used in ATEX zones.
- In order to keep the ATEX approval, always use original spares from Orbinox.
 - Washer → DIN 6798A (This washer guarantees continuity among carbon steel parts, coated in epoxy, yoke and body and stainless steel guards for coating thicknesses up to 200 microns)
 - ST and GR packing →
 - ORBINOX ST: Synthetic packing impregnated with PTFE
 - GR: Graphite packing → MONTERO Ecograflex 780R
- After any maintenance of ATEX valves, it is mandatory to check that the valve is earthed through the pipe, and there is continuity among the different valve components, such as the body, the gate, the supports, and guards (test in accordance with EN 12266-2 Standard, annex B, points B.2.2.2. and B.2.3.1).

MAXIMUM FLUID TEMPERATURES

Atmosphere	
Gas/air, steam/air, and mist/air	Dust/air
80% of minimum fluid ignition temperature, minus 10°K	2/3 of minimum dust cloud ignition temperature minus 85°K

Note: these maximum fluid temperatures apply to all categories. The differences between categories are the consideration of foreseeable malfunction cases and rare malfunctions cases

MAXIMUM SEAL AND PACKING TEMPERATURES

Max Temperature (°C)	SEAL			
	EPDM	VITON	NITRILE	GRAPHITE
	120	200	120	600

Max Temperature (°C)	PACKING	
	ST	GRAPHITE
	240	600

Note: Most of the times seals maximum temperature capacity is the key limitation factor when evaluating valve maximum working temperatures. In ATEX zones these temperatures must be compared to those above related to limitation of fluids temperatures. Always consider the most restrictive as maximum valve working temperature.

5.- STORAGE

For long periods it is recommended to store the valves in a well-ventilated room. Valves should not be exposed to temperatures higher than 30°C, as some soft seal materials can be damaged when exposed to higher temperatures.

If outdoor storage cannot be avoided, cover the valve and protect it from sources of heat or direct sunlight. Provide good ventilation to avoid moisture.

6.- PARTS LIST & DRAWINGS

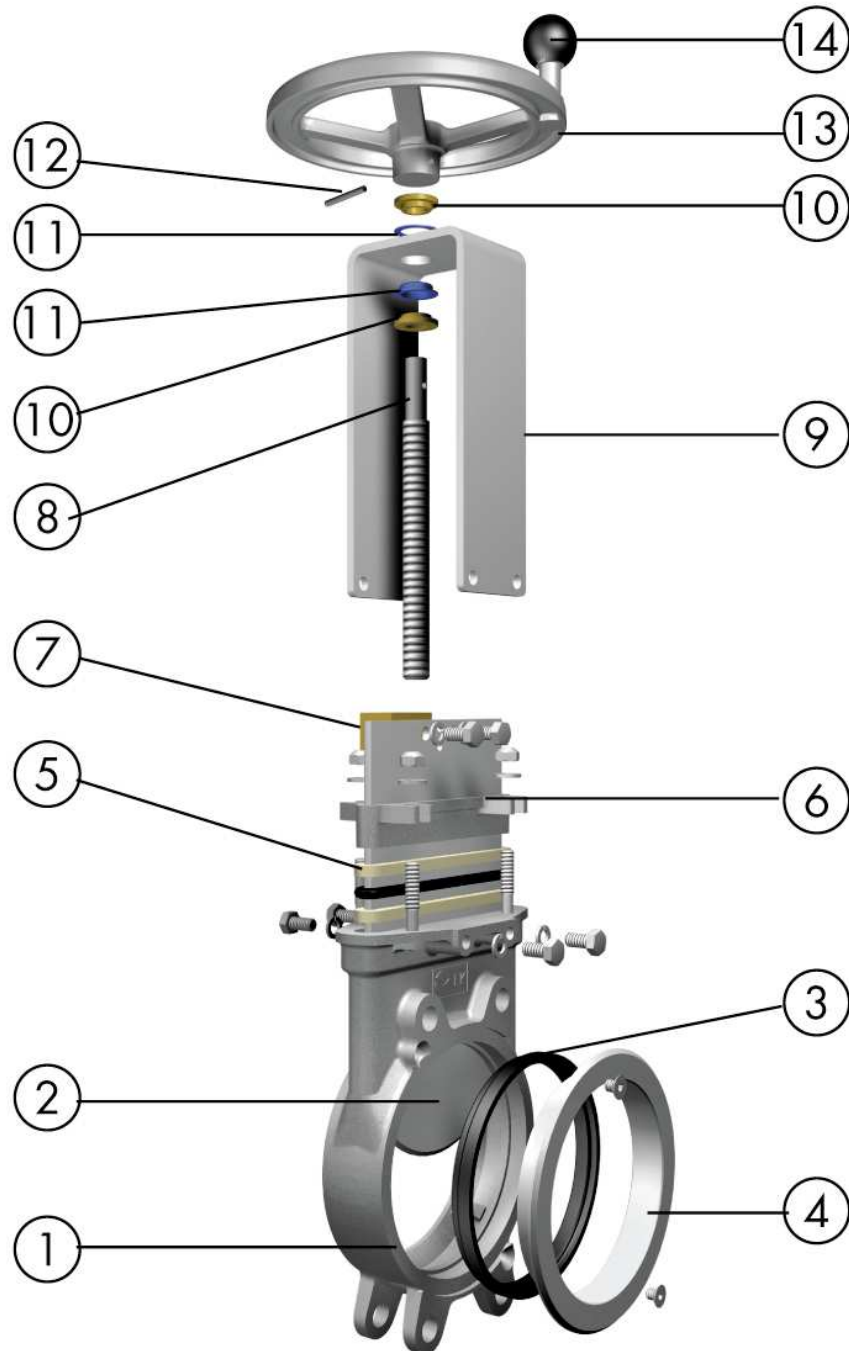

- 1. - BODY
- 2. - GATE
- 3. - SEAL
- 4. - O-RING (Only with PTFE seat)
- 5. - "K" RING
- 6. - PACKING
- 7. - GLAND

- 8. - STEM NUT
- 9. - STEM
- 10. - YOKE
- 11. - BUSHING
- 12. - BUSHING + WASHER
- 13. - SPRING PIN
- 14. - HANDWHEEL
- 15.- KNOB