

MODEL**TL**

THROUGH CONDUIT KNIFE GATE VALVE

The **TL** model knife gate is a bi-directional wafer valve designed for media with high consistency. The double seat design assures a non-clogging shut off on either normal or reverse flow. The valve is used in a wide range of demanding applications in industries such as:

- Pulp & Paper • Wastewater Treatment Plants • Power Plants
- Chemical plants • etc.

Sizes: DN 50 to DN 1000 (larger diameters on request)

Working pressure:

DN 50 to DN 125:	10 kg/cm ²
DN 150 to DN 250:	8 kg/cm ²
DN 300 to DN 400:	6 kg/cm ²
DN 450:	5 kg/cm ²
DN 500 to DN 600:	4 kg/cm ²
DN 700 to DN 1000:	2 kg/cm ²

Standard flange connection: DIN PN 10 and ANSI B16.5 (class 150)

Note: other flange connections are available on request such as:
 DIN PN 6 DIN PN 16 DIN PN 25
 BS "D" and "E" ANSI 125

Directives: DIR 2006/42/EC (MACHINES)
 DIR 97/23/EC (PED) Fluid: Group 1(b), 2 (Cat. I, mod. A)
 DIR 94/9/EC (ATEX)



All valves are tested prior to shipping in accordance with the standard developed by the Quality Control Department at ORBINOX.

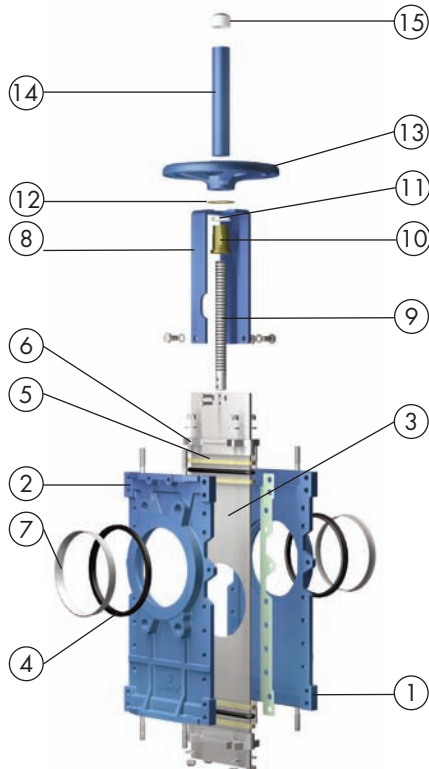

STANDARD PARTS LIST

Part:	Cast Iron:	Stainless Steel:
1- Body	GJL 250 (GG25)	CF8M
2- Body	GJL 250 (GG25)	CF8M
3- Gate	AISI 304	AISI 316
4- Seat	Metal or EPDM	.Metal/ Metal
5- Packing	PTFE Impreg. Synth. Fibre (With a EPDM o-ring)	
6- Gland Follower	Aluminium (DN 50 to DN 300) Ductile Iron (DN 350 to DN 1000)	CF8M
7- Seat Retainer Ring	AISI 304	-
8- Yoke	Carbon Steel - Epoxy Coated	
9- Stem	AISI 430	
10- Stem nut	Brass	
11- Collar	Nylon	
12- Friction washer	Brass	
13- Handwheel	$\phi \leq 310$: Ductile Iron / $\phi \geq 410$: GJL 250 (GG25)	
14- Stem Protector	Epoxy-coated Carbon Steel	
15- Cap	Plastic	

DESIGN FEATURES

BODY:

Wafer style cast two-part bolted body, internally machined, with reinforced ribs in larger diameters for extra body strength.

Internal UHMW Polyethylene sliders for smoother gate travel (stainless steel version only).

Full port design for greater flow capacity and minimal pressure drop.

SELF-CLEANING GATE:

Stainless steel gate as standard. One piece gate with o-port design.

While closing, the gate moves a disc of material laterally which returns to the flow when opening.

Gate is polished on both sides for a greater seal between the gate with both packing and seat.

On request: thickness and/or material of the gate can be changed for higher pressure requirement.

SEAT: (resilient)

Unique design that mechanically locks the seat in the internal of the valve body with a stainless steel retainer ring.

Standard EPDM; also available in different materials such as Viton, PTFE, etc.

PACKING:

Double stuffing box with several layers of braided fibre plus an EPDM o-ring, with an easy access packing gland ensuring a tight seal.

Long-life braided packing is available in a wide range of materials.

STEM:

The standard stainless steel stem offers a long corrosion resistant life.

For rising stem handwheel actuators only, a stem protector is provided for additional protection against dust while the valve is in the open position.

ACTUATORS:

All actuators supplied by **ORBINOX** are interchangeable, and supplied with an standard mounting kit to allow for installation on site.

YOKE or ACTUATOR SUPPORT:

Made of EPOXY coated steel (stainless steel available on request).

Compact design makes it extremely robust even under the most severe conditions.

EPOXY COATING:

The epoxy coating on all **ORBINOX** cast iron and carbonsteel valve bodies and components is electrostatically applied making the valves to be corrosion resistant with a high quality finished surface.

The **ORBINOX** standard colour is RAL-5015 blue.

GATE SAFETY PROTECTION:

ORBINOX automated valves are provided with gate guards in accordance with EU Safety Standards.

The design feature prevents any objects from being caught accidentally while the gate is moving.



OTHER OPTIONS

Bonnet (Fig.1):

Assures tight sealing to atmosphere for using with hazardous gas or fluids.
Reduces packing maintenance.

Diamond port:

Excellent flow regulation.

Flush ports:

Allow for cleaning of solids trapped within the body cavities that can obstruct the flow or prevent the valve from closing.
Purging can be made with air, steam, liquids, etc. depending on the process.

Other materials of construction:

Special alloys such as AISI 317, 254SMO, Hastelloys, Titanium, etc.

Fabricated valves:

ORBINOX is equipped for in house fabrication of special valves.
Depending on the design, diameter, pressures, construction material, etc.

Square port (Fig.2):

Greater flow capacity for bulk material.
Designed for equipment with square flange connections.

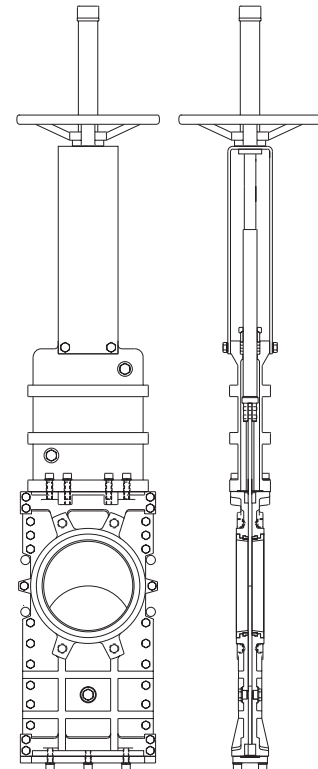

Fig. 1

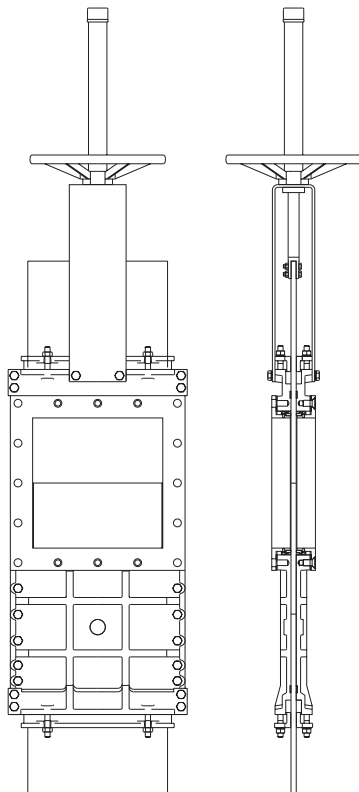

Fig. 2

SURFACE TREATMENTS

Valve components can be protected or coated for a longer life expectancy, depending on the application and the service conditions,

At **ORBINOX** we can offer treatments and coatings for the valve components to improve the properties against **abrasion** (Stellite, Polyurethane...), **corrosion** (Halar, Rilsan, Galvanised...) and **adherence** (Polishing, PTFE...).

ATEX



Please contact our Orbinox representative for info and availability. Some considerations:

- Hand operated TL valves have been subjected to an ignition risk assessment according to DIN EN 13463: 1-5 and they are out the scope of application of ATEX Directive. Therefore hand operated valves are suitable for ALL ATEX zones.
- Electrical, pneumatical and hydraulically operated valves must be subjected to a conformity assesment of their own and also of the whole unit valve-actuator to get EC Type Approval to Directive 94/9.

ACTUATOR TYPES

Manual:

Handwheel (rising & non-rising stem)
 Chainwheel
 Lever
 Bevel Gear
 Others (square nut...)

Automatic:

Electric
 Double Acting Pneumatic
 Single Acting Pneumatic
 Hydraulic

All actuators supplied by ORBINOX are interchangeable.

FAIL SAFE SYSTEMS

Used on pneumatic actuated valves,

SINGLE ACTING / SPRING RETURN

Available from DN 50 to DN 200

Options:

- Fail open
- Fail closed

SINGLE ACTING / VOLUME TANK

Available for all sizes (DN>200)

Options:

- Pneumatic Failsafe
- Pneumatic or Electric Failsafe

ACCESSORIES

Mechanical stops
 Locking device
 Manual override
 Solenoid valves
 Positioners
 Limit switches
 Proximity switches
 Floor stands
 Stem extensions

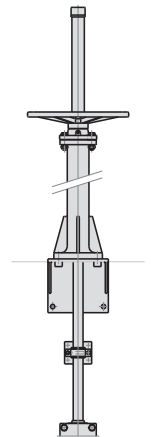

Wide range of extensions available.

For further information about fail safe systems and valve extensions, see EX chapter.

We recommend consultation with our technical department.

TEMPERATURE CHART

SEAT / SEALS			PACKING		
Material	Max.Temp.(°C)	Applications	Material	Max. Temp. (°C)	pH
Metal/Metal	>250	High temp. Low tightness.	Dry cotton (AS)	50	6 - 8
EPDM (E)	120	Acids and non mineral oils.	PTFE impregn. synth. fibre (ST)	240	2 - 13
Nitrile (N)	120	Resistance to petroleum products.	Braided PTFE (TH)	260	0 - 14
Viton (V)	200	General chemical service. High temperature.	Graphited (GR)	600	0 - 14
Silicone (S)	250	Food service. / High temperature.	Ceramic fibre (FC)	1200	—
PTFE (T)	250	Corrosion resistance.			

NOTE: all types include an elastomere O-ring (same material as seal), excluding TH, GR and FC.

More details and other materials under request.

SEAT TYPES

Cast Iron

Stainless Steel

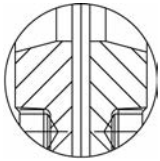

METAL / METAL

Used for high temperature or in applications where tight shutoff is not required. UHMW polyethylene seat sliders for smoother gate travel (stainless steel version only).

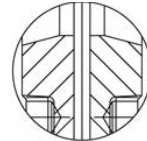

DN 50 - 150

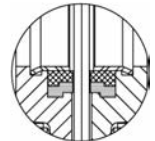

DN 200 - 600

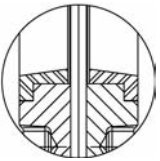

METAL / METAL, TYPE "B"

Two replaceable reinforced "B" type rings (available in AISI 316, Ni-hard, CA-15,...) protect the seat in abrasive services. UHMW polyethylene seat sliders for smoother gate travel (stainless steel version only).

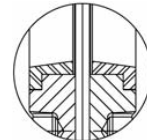

DN 50 - 150

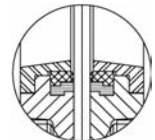

DN 200 - 600



RESILIENT, TYPE "A"

The standard resilient seat design consists of an elastomer seal locked to the valve body with a replaceable stainless steel retainer ring. Temperature limitations according to seat material selected. Consult the above chart or our technical department for more information. UHMW polyethylene seat sliders for smoother gate travel (stainless steel version only).

See option TK valve

See option TK valve

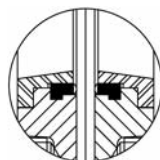

RESILIENT, TYPE "B"

The two replaceable reinforced seal retainer rings (available in AISI 316, Ni-hard, CA-15,...) protect the seat in abrasive services. Temperature limitations according to seat material selected. Consult the above chart or our technical department for more information. UHMW polyethylene seat sliders for smoother gate travel (stainless steel version only).

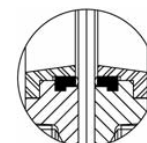

DN 50 - 150

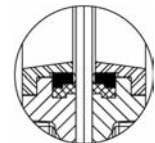

DN 200 - 600

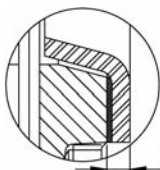

DEFLECTION CONE "C"

Deflects the media away from any internal exposed parts of the valve such as gate guides, seat, etc. Different types of material available such as AISI 316 stainless, CA15, Ni-Hard, etc.

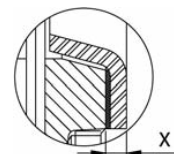

X Face to face dimensions increase: DN 50 to DN 250 X = 9mm
DN 300 to DN 600 X = 12mm

HANDWHEEL (rising stem)

- Standard handwheel actuator
- Consists of:
 - Handwheel: Epoxy coated Cast Iron
 - Stem
 - Stem nut
 - Stem protector
- Available from DN 50 to DN 600
- Options (on request):
 - Locking Device
 - Extensions

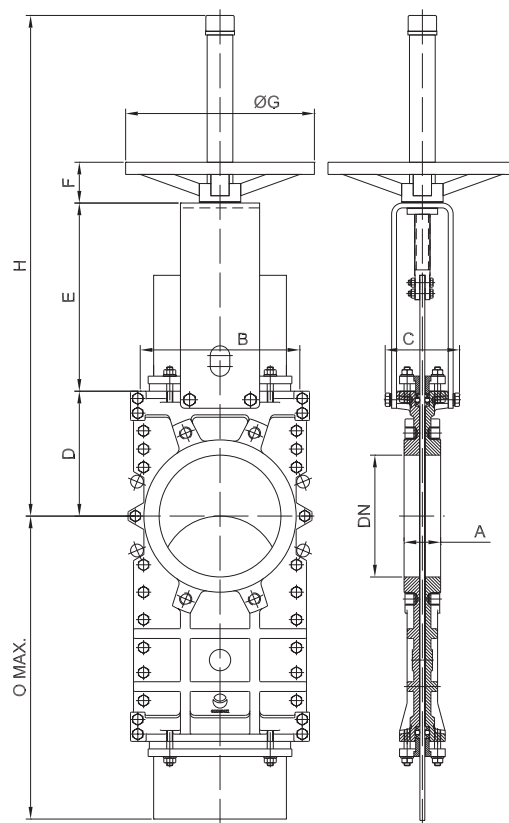

DN	A	B	C	D	E	F	ØG	H	O max.	Weight (kg.)
50	40	152	100	110	129	47	225	429	232	12
65	40	167	100	115	146	47	225	451	255	14
80	50	182	100	124	162	47	225	476	310	16
100	50	202	100	140	187	47	225	517	367	20
125	50	216	100	150	211	47	225	601	432	29
150	60	241	100	175	237	47	225	652	497	35
200	60	294	122	205	309	67	310	822	635	62
250	70	356	122	245	364	67	310	1017	777	89
300	70	410	122	280	414	67	310	1102	905	110
350	96	473	197	300	486	66	410	1286	1047	174
400	100	538	197	350	536	66	410	1386	1171	266
450	106	588	201	420	588	66	550	1583	1301	326
500	110	646	201	450	648	66	550	1673	1461	372
600	110	754	201	530	748	66	550	1963	1711	445

HANDWHEEL (non-rising stem)

- Recommended for installation where space is limited
- Consists of:
 - Handwheel: Epoxy coated Cast Iron
 - Stem
 - Yoke bushing
 - Stem nut fixed to the gate
- Available from DN 50 to DN 600
- Options (on request):
 - Locking Device
 - Extension
 - Square Nut Drive

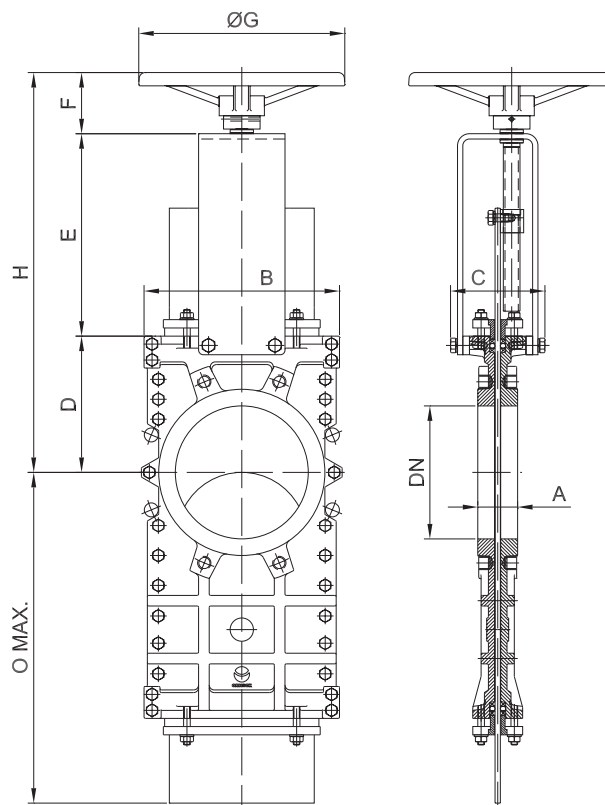

DN	A	B	C	D	E	F	ØG	H	O max.
50	40	152	125	110	132	78	225	320	232
65	40	167	125	115	149	78	225	342	255
80	50	182	125	124	165	78	225	367	310
100	50	202	125	140	190	78	225	408	367
125	50	216	125	150	214	78	225	442	432
150	60	241	125	175	240	78	225	493	497
200	60	294	142	205	305	92	310	602	635
250	70	356	142	245	360	92	310	697	777
300	70	410	142	280	410	92	310	782	905
350	96	473	197	300	487	110	410	897	1047
400	100	538	197	350	537	110	410	997	1171
450	106	588	201	420	589	111	550	1120	1301
500	110	646	201	450	649	111	550	1210	1461
600	110	754	201	530	748	111	550	1389	1711

CHAINWHEEL

- Recommended for elevated installations
- Consists of:
 - Chainwheel: Epoxy coated Cast Iron
 - Stem
 - Stem nut
 - Stem protector
- Available from DN 50 to DN 600
- Options (on request):
 - Locking Device
 - Extension
 - Non-rising Stem

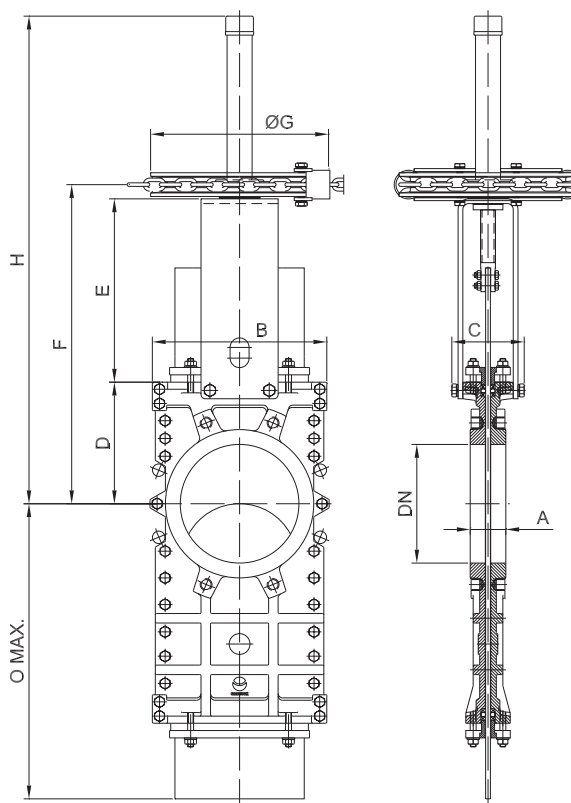

DN	A	B	C	D	E	F	ØG	H	O max.
50	40	152	100	110	129	258	225	429	232
65	40	167	100	115	146	280	225	451	255
80	50	182	100	124	162	305	225	476	310
100	50	202	100	140	187	347	225	518	367
125	50	216	100	150	211	380	225	601	432
150	60	241	100	175	237	431	225	652	497
200	60	294	122	205	309	538	300	822	635
250	70	356	122	245	364	633	300	1017	777
300	70	410	122	280	414	718	300	1102	905
350	96	473	197	300	486	818	454	1285	1047
400	100	538	197	350	536	918	454	1385	1171
450	106	588	201	420	588	1040	454	1577	1301
500	110	646	201	450	648	1130	454	1672	1461
600	110	754	201	530	748	1310	454	1962	1711

GEAR

- Recommended for valves larger than DN 350 and working pressures greater than 3.5 kg/cm²
- Consists of:
 - Stem
 - Yoke
 - Bevel Gear Actuator with Handwheel (Standard Ratio 4:1)
- Available from DN 200 to DN 600
- Options (on request):
 - Locking Device
 - Extension
 - Chainwheel
 - Non-rising stem

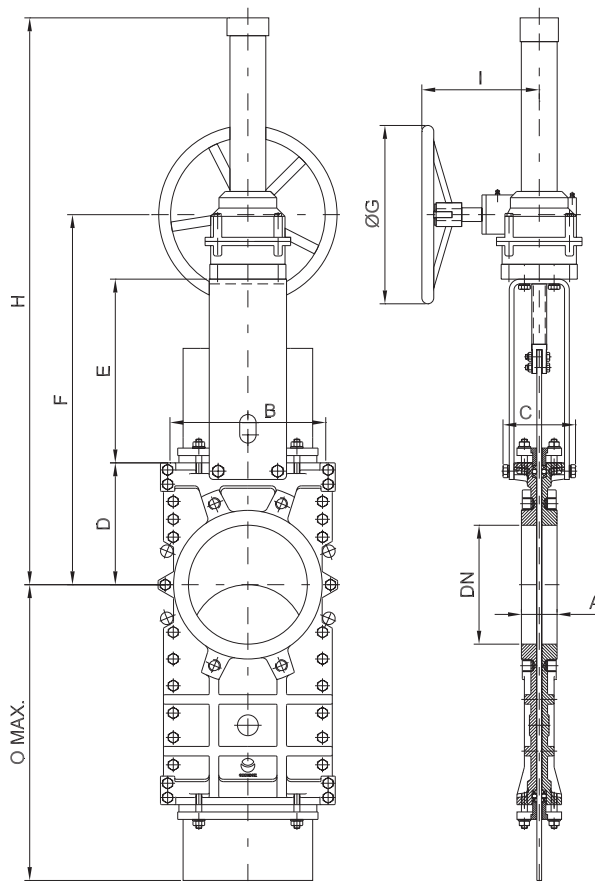

DN	A	B	C	D	E	F	ØG	H	I	O max.
200	60	294	122	205	309	584	300	994	200	635
250	70	356	122	245	364	679	300	1089	200	777
300	70	410	122	280	414	744	300	1154	200	905
350	96	473	197	300	486	836	450	1536	270	1047
400	100	538	197	350	536	936	450	1636	270	1171
450	106	588	201	420	588	1058	450	1758	270	1301
500	110	646	201	450	648	1148	450	1848	270	1461
600	110	754	201	530	748	1328	450	2028	270	1711

PNEUMATIC CYLINDER

- The standard pneumatic actuator (double acting on-off cylinder) consists on:
 - Aluminium jacket and covers
 - Stainless Steel (AISI 304) piston rod
 - Nitrile coated steel piston
- Available in DN 50 to DN 600
- Supply Pressure: minimum 3.5 kg/cm² - maximum 10 kg/cm²
Actuator designed with 6 kg/cm² air supply
- For valves installed in a horizontal position, we recommend U-type support plates and/or actuator support.
- Options:
 - Hard anodized jacket and covers
 - Over / Undersized cylinder
 - Stainless Steel jacket and covers
 - Manual override
 - Fail Safe System
 - Travel stops
- Instrumentation (on request):
 - Positioners
 - Solenoid valves
 - Flow regulators
 - Air preparation units

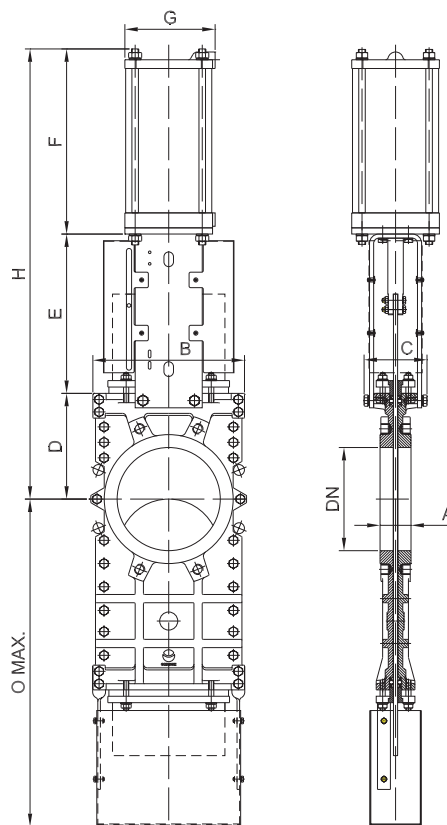

DN	A	B	C	D	O max.	E	F	G	H	Weight (kg.)	Standard Cyl.	Connect.
50	40	152	100	110	232	129	178	115	417	14	C100/62	1/4" G
65	40	167	100	115	255	146	193	115	454	16	C100/77	1/4" G
80	50	182	100	124	310	162	211	115	497	18	C100/95	1/4" G
100	50	202	100	140	367	187	231	115	558	23	C100/115	1/4" G
125	50	216	100	150	432	211	271	140	632	34	C125/143	1/4" G
150	60	241	100	175	497	237	296	140	708	41	C125/168	1/4" G
200	60	294	122	205	635	309	358	175	872	73	C160/220	1/4" G
250	70	356	122	245	777	364	428	220	1037	105	C200/270	3/8" G
300	70	410	122	280	905	414	478	220	1172	128	C200/320	3/8" G
350	96	473	197	300	1047	510	535	277	1345	207	C250/375	3/8" G
400	100	538	197	350	1171	560	585	277	1495	300	C250/425	3/8" G
450	106	588	270	420	1301	608	665	382	1693	378	C300/475	1/2" G
500	110	646	270	450	1461	668	715	382	1833	445	C300/525	1/2" G
600	110	754	270	530	1711	796	880	444	2206	619	C350/625	3/4" G

ELECTRIC ACTUATOR

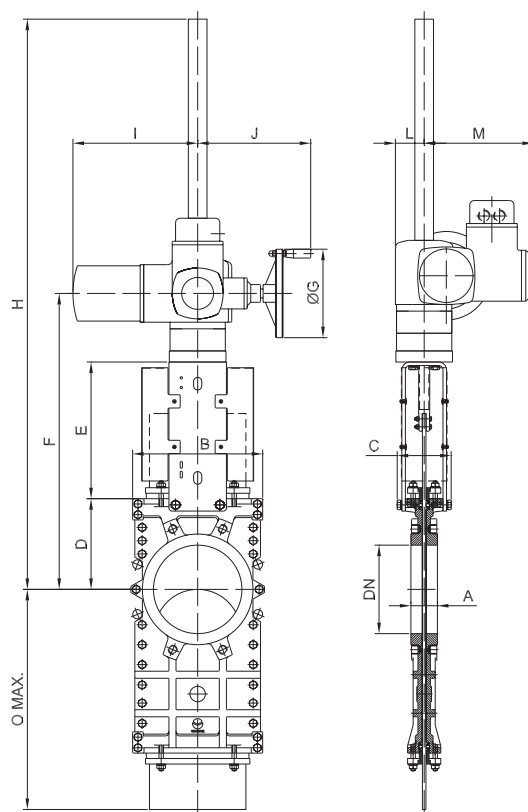

- Consists of:
 - Electric motor
 - Rising stem
 - Motor support yoke
(Acc. to ISO 5210/DIN 3338)
- The standard electric motor is equipped with:
 - Manual emergency operation
 - Limit switches (open/closed)
 - Torque switches
- Available from DN 50 to DN 600
- Wide range of types and marks available to meet customer's needs.
- Option:
 - Non rising stem



DN	A	B	C	D	E	F	ØG	H	O max.	I	J	L	N	stem Ø x pitch	Torque(Nm)
50	40	152	100	110	129	357	160	527	232	265	249	62	237	20 x 4	10
65	40	167	100	115	146	379	160	549	255	265	249	62	237	20 x 4	10
80	50	182	100	124	162	404	160	574	310	265	249	62	237	20 x 4	10
100	50	202	100	140	187	445	160	615	367	265	249	62	237	20 x 4	10
125	50	216	100	150	211	479	160	649	432	265	249	62	237	20 x 4	15
150	60	241	100	175	237	530	160	1100	497	265	249	62	237	20 x 4	25
200	60	294	122	205	309	632	160	1252	635	265	249	62	237	25 x 5	35
250	70	356	122	245	364	739	200	1319	777	282	256	65	247	25 x 5	60
300	70	410	122	280	414	824	200	1409	905	282	256	65	247	25 x 5	70
350	96	473	197	300	510	940	200	1525	1047	282	256	65	247	35 x 6	100
400	100	538	197	350	560	1085	315	1670	1171	383	325	90	285	35 x 6	140
450	106	588	270	420	608	1203	315	1803	1301	383	325	90	285	35 x 6	180
500	110	646	270	450	668	1293	315	1893	1461	383	325	90	285	35 x 6	170
600	110	754	270	530	796	1505	315	2205	1711	383	325	90	285	35 x 6	220



FLANGE AND BOLTING DETAILS

EN 1092-2 PN10

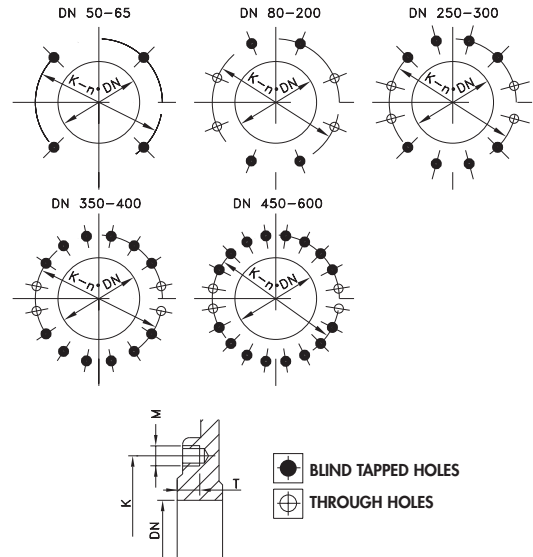
DN	K	n°	M	T	 
50	125	4	M-16	11	4 - -
65	145	4	M-16	11	4 - -
80	160	8	M-16	14	4 - 4
100	180	8	M-16	14	4 - 4
125	210	8	M-16	14	4 - 4
150	240	8	M-20	18	4 - 4
200	295	8	M-20	18	4 - 4
250	350	12	M-20	22	8 - 4
300	400	12	M-20	22	8 - 4
350	460	16	M-20	28	12 - 4
400	515	16	M-24	28	12 - 4
450	565	20	M-24	32	16 - 4
500	620	20	M-24	32	16 - 4
600	725	20	M-27	32	16 - 4



ANSI B16.5, class 150

DN	K	n°	M	T	 
2"	4 3/4"	4	5/8" UNC	7/16"	4 - -
2 1/2"	5 1/2"	4	5/8" UNC	7/16"	4 - -
3"	6"	4	5/8" UNC	9/16"	4 - -
4"	7 1/2"	8	5/8" UNC	9/16"	4 - 4
5"	8 1/2"	8	3/4" UNC	9/16"	4 - 4
6"	9 1/2"	8	3/4" UNC	11/16"	4 - 4
8"	11 3/4"	8	3/4" UNC	11/16"	4 - 4
10"	14 1/4"	12	7/8" UNC	7/9"	8 - 4
12"	17"	12	7/8" UNC	7/9"	8 - 4
14"	18 3/4"	12	1" UNC	1 1/8"	8 - 4
16"	21 1/4"	16	1" UNC	1 1/8"	12 - 4
18"	22 3/4"	16	1 1/8" UNC	1 1/4"	12 - 4
20"	25"	20	1 1/8" UNC	1 1/4"	16 - 4
24"	29 1/2"	20	1 1/4" UNC	1 1/4"	16 - 4

