

Operating Instructions

ERHARD Tilting-Disc Check Valves

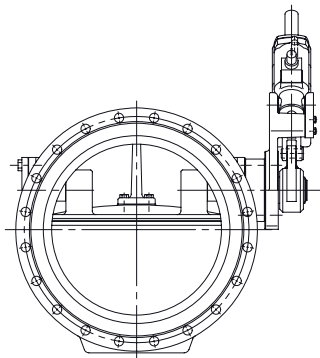

with weight-load.lever + oleohydr. damping device



- 1 Safety Aspects
- 2 Description of Product and Range of Application
- 3 Design Features – Technical Data
- 4 Performance and Mode of Operation
- 5 Installation into the Pipeline – Mounting
- 6 Maintenance
- 7 Design with oleohydraulic damping device

These operating instructions must always be used in combination with operating instructions BA01E001!

1 Safety Aspects

According to the stipulations concerning safety for technical equipment (DIN 31000 and following) as well as the respective regulations for prevention of accidents (UVV) it is necessary to restrict access to the moving range of the weight-loaded lever and the oleohydraulic damping device. Effective protective guards have to be installed by customers.

On request we will supply suitable protective guards.

2 Description of Product and Range of Application

Nominal size DN	Nominal pressure PN	Hydrostatic test pressure in bars for		Max. admissible working pressure in bars at a working temperature of	
		body	seat	> 70° C	Product No.
200-1200	10	15	10	10	5503 ..59
150-1200	16	24	16	16	5504 ..59
150-1000	25	37.5	25	25	5505 ..59

Operating Instructions for ERHARD Tilting-Disc Check Valves with weight-loaded lever and oleohydraulic damping device

At the manufacturer`s plant the valve have been tested for tightness and strength to DIN EN12 266.

The ERHARD Tilting-Disc Check Valves
is put on for water speeds under stable flow rates according to table:

values according to EN1074-1: 2000

PFA bar	Velocity of flow m/s
10	3
16	4
25	5

**Operating Instructions for ERHARD Tilting-Disc Check Valves
with weight-loaded lever and oleohydraulic damping device**

3 Design Features – Technical Data

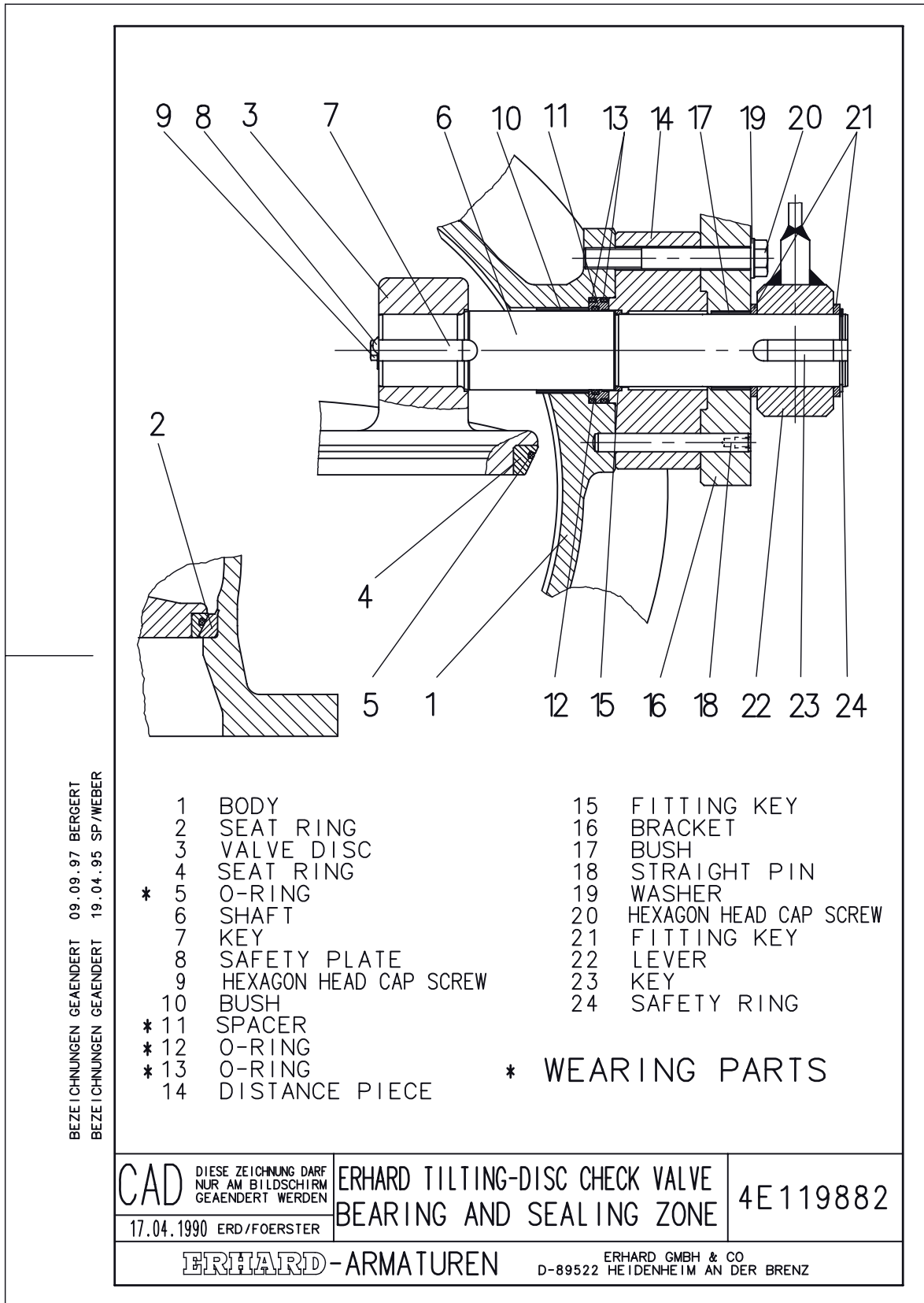

Operating Instructions for ERHARD Tilting-Disc Check Valves with weight-loaded lever and oleohydraulic damping device

© TEXT RICHTIG GESTELLT 28.07.97 GA

MEASURED CHARACTERISTIC CURVE OF THE ERHARD TILTING-DISC CHECK VALVE
DUCTILE CAST IRON SG GGG SS/SS DN500 PN10 WITH WEIGHT-LOADED LEVER
FOR INSTALLATION INTO HORIZONTAL WATER PIPELINE

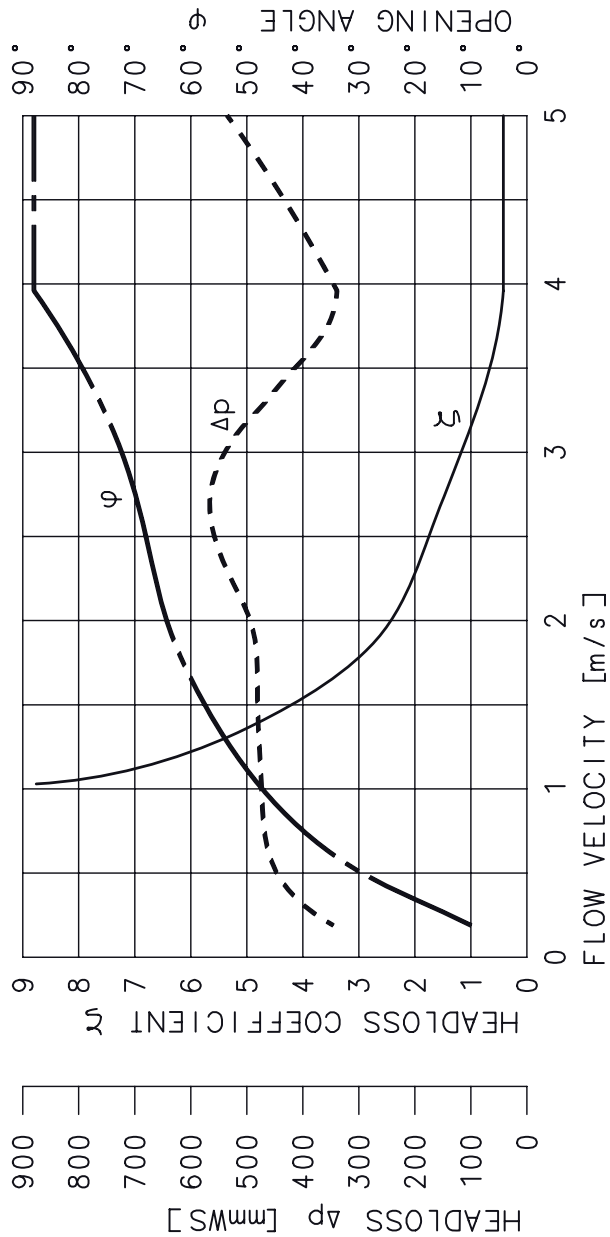

CAD DIESE ZEICHNUNG DARF NUR AM BILDSCHIRM GEÄNDERT WERDEN

13.03.1990 KE/FOERSTER

ERHARD TILTING-DISC CHECK VALVE
SG GGG SS/SS DN500 PN10
MEASURED CHARACTERISTIC CURVES

4E111128

ERHARD-ARMATUREN

JOHANNES ERHARD, H. WALDENMAIER ERBEN
SUEDEUTSCHE ARMATURENFABRIK GMBH&CO
7920 HEIDENHEIM AN DER BRENZ

Operating Instructions for ERHARD Tilting-Disc Check Valves with weight-loaded lever and oleohydraulic damping device

Horizontal main

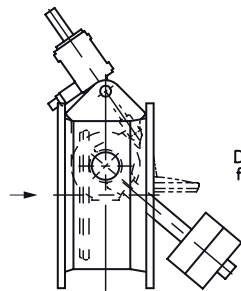

Fig 1
Weight-loaded lever
and damping cylinder
on the left, seen in
direction of flow

Direction of
flow

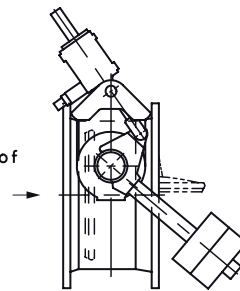

Fig 2
Weight-loaded lever
and damping cylinder
on the right, seen in
direction of flow

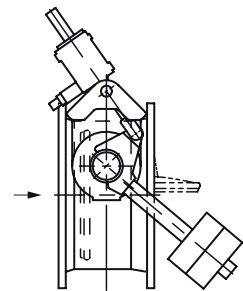

Fig 3
Weight-loaded lever
and damping cylinder
on both side

Vertical main

Vertically upward direction of flow

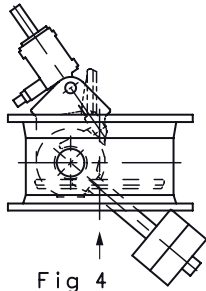

Fig 4

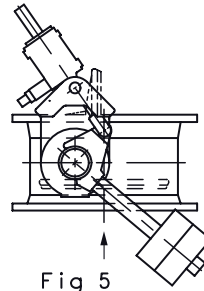

Fig 5

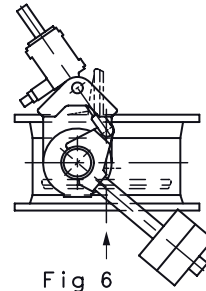

Fig 6
Weight-loaded lever
and damping cylinder
on both side

Vertically downward direction of flow

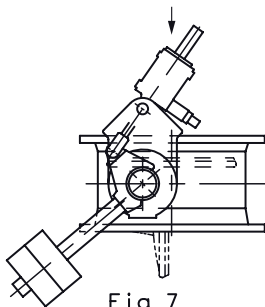

Fig 7

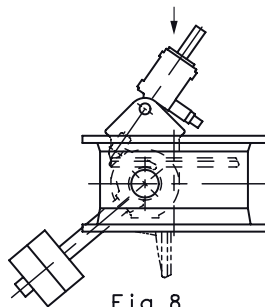

Fig 8

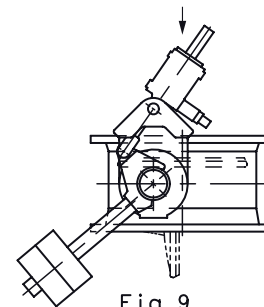

Fig 9
Weight-loaded lever
and damping cylinder
on both side

When placing the order, please state Fig.No. for arrangement
of hydraulic damping device with weight-loaded lever

CAD DIESE ZEICHNUNG DARF
NUR AM BILDSCHIRM
GEÄNDERT WERDEN

27.01.1993 ERD/

ERHARD-CHECK VALVE

Arrangement of hydraulic damping
cylinder weight-loaded lever

4E106000

ERHARD-ARMATUREN

ERHARD GMBH & CO
D-89522 HEIDENHEIM AN DER BRENZ

ZCHNG. BERICHTIGT 05.09.95 JAN/BER

**Operating Instructions for ERHARD Tilting-Disk Check Valves
with weight-loaded lever and oleohydraulic damping device**

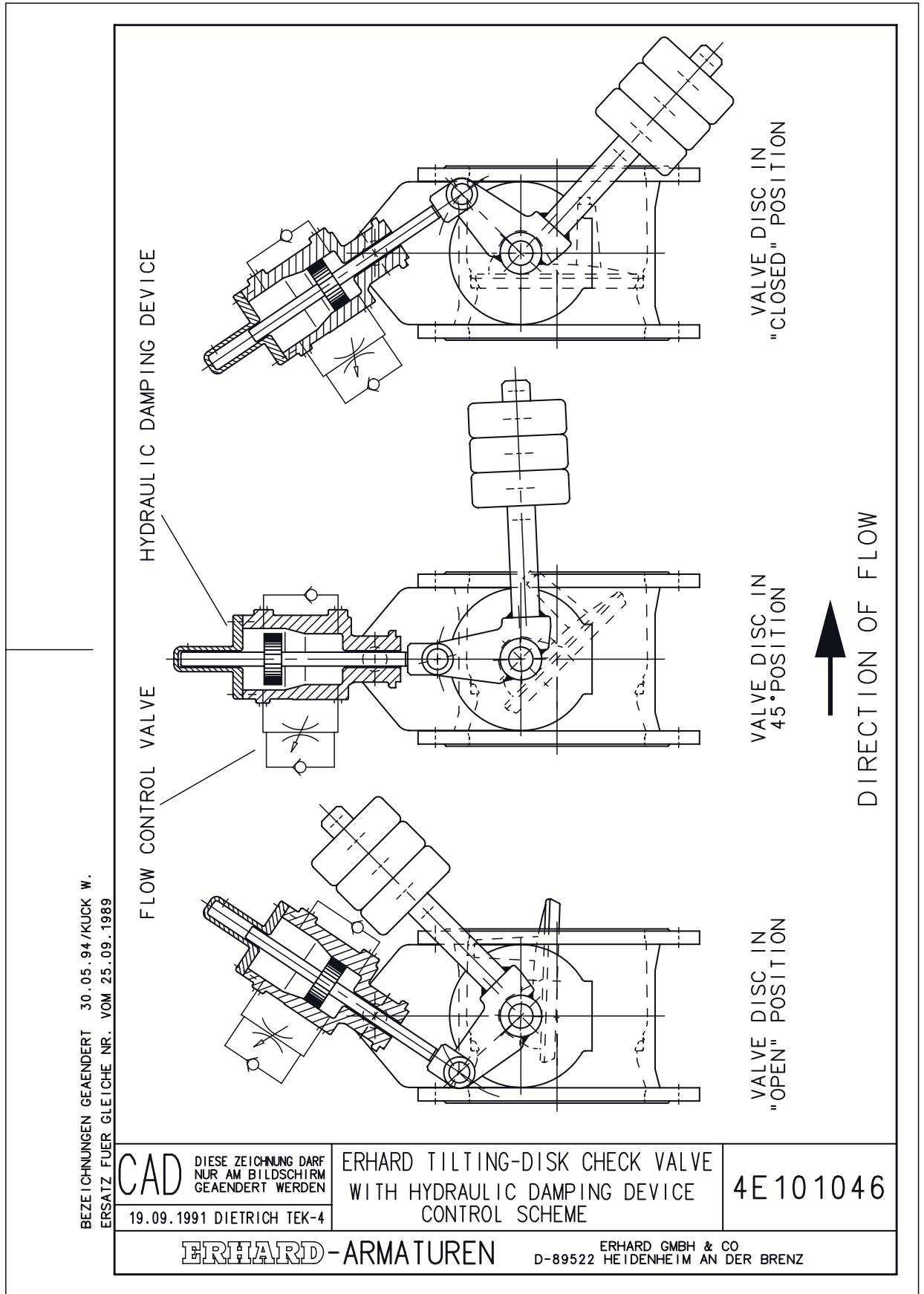

Operating Instructions for ERHARD Tilting-Disc Check Valves with weight-loaded lever and oleohydraulic damping device

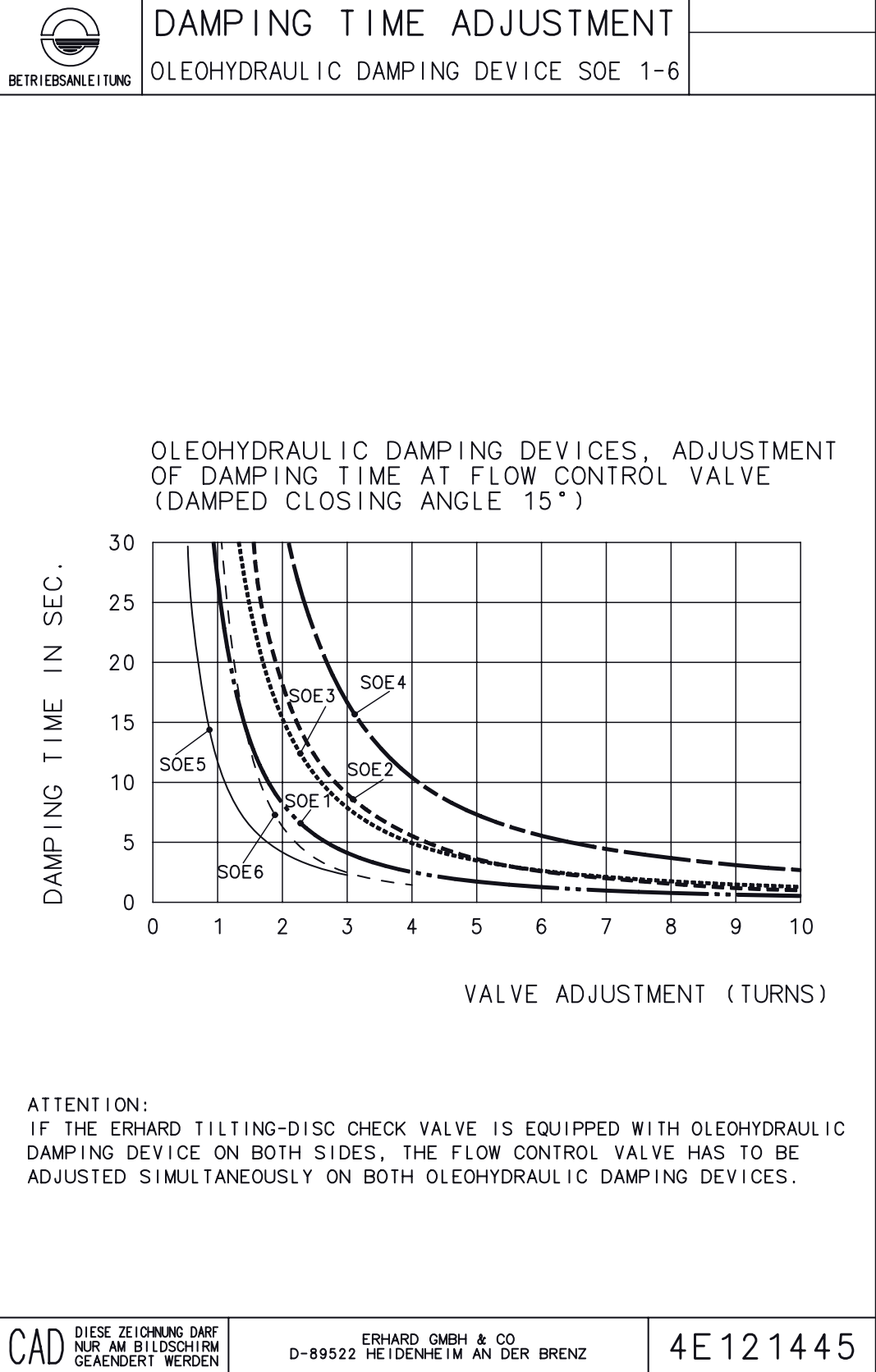

**Operating Instructions for ERHARD Tilting-Disc Check Valves
with weight-loaded lever and oleohydraulic damping device**

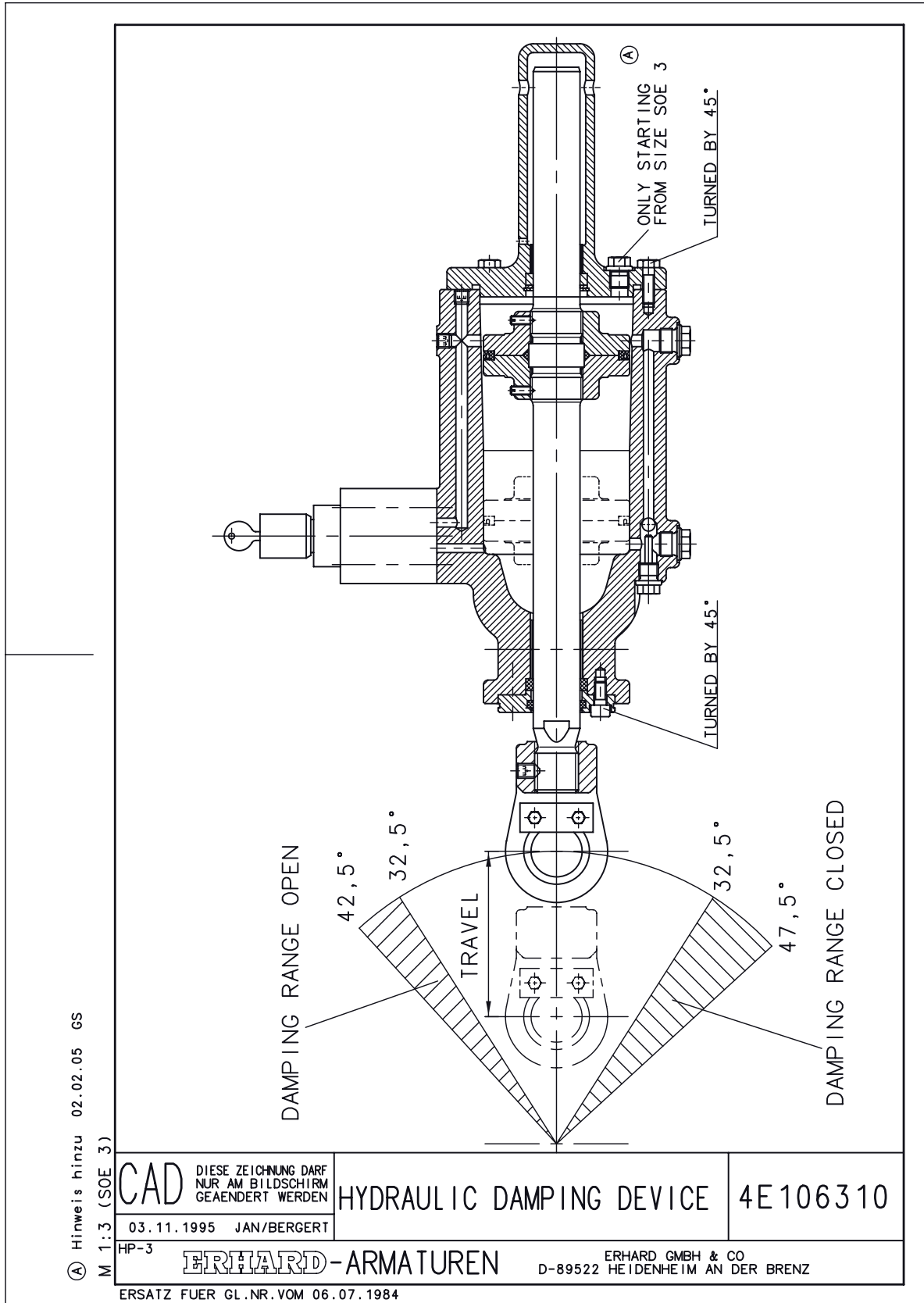

Operating Instructions for ERHARD Tilting-Disc Check Valves with weight-loaded lever and oleohydraulic damping device

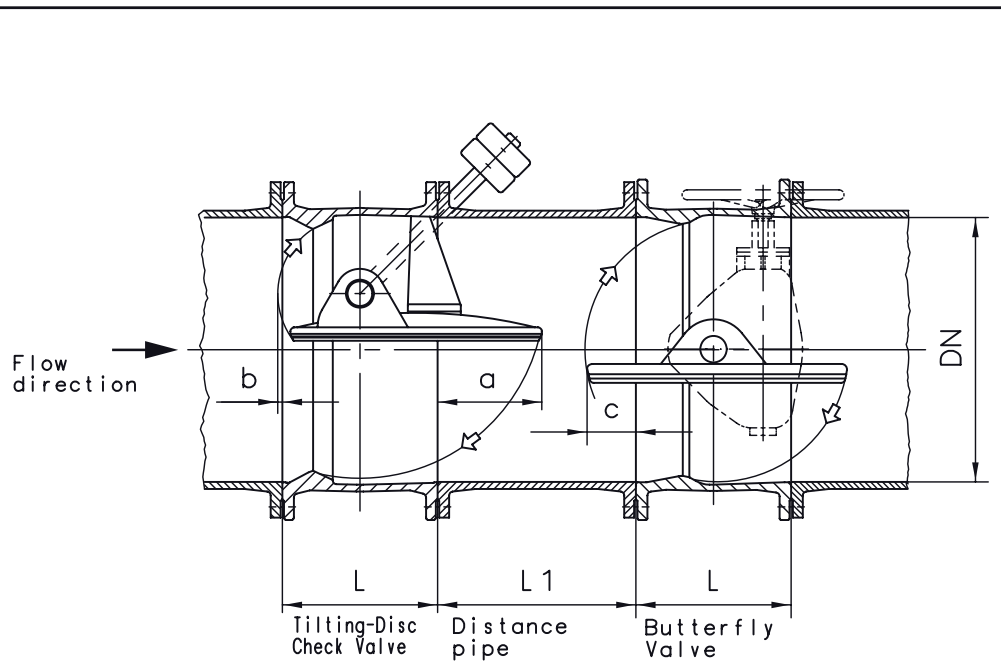

DN	L	L1	a	b	c
150	210				
200	230	150	20		
250	250	150	45		
300	270	150	70		2
350	290	200	95		25
400	310	225	118		40
450	330	250	142		55
500	350	300	165		65
600	390	400	215		95
700	430	500	263	10	120

DN	L	L1	a	b	c
800	470	600	315	15	150
900	510	650	364	30	180
1000	550	750	410	40	210
1100	590	800	455	55	225
1200	630	900	515	62	270
1300	670	1000	560	60	295
1400	710	1100	615	80	320
1500	750	1200	660	80	360
1600	790	1300	705	90	385
1800	870	1400	815	110	445
2000	950	1600	915	130	505

All dimensions in mm

ATTENTION:

The valve has to be installed in such a way that the weight-loaded lever of the ERHARD Check Valve is located on the left seen in flow direction, and the gearbox of the ERHARD Butterfly Valve on the right in flow direction. Thus, there is no collision of weight-loaded lever and gearbox.

① MASSE GEÄNDERT

CAD DIESE ZEICHNUNG DARF NUR AM BILDSCHIRM GEÄNDERT WERDEN

SUGGESTED INSTALLATION

4E 98300

22.05.1995 MB/LUTZ HP 2

ERHARD TILTING-DISC CHECK VALVE - ERHARD BUTTERFLY VALVE

ERHARD-ARMATUREN

ERHARD GMBH & CO
D-89522 HEIDENHEIM AN DER BRENZ

ERSETZT FUER BLATT GLEICHER NUMMER V. 14.10.1981

4 Performance and Mode of Operation

The ERHARD Tilting-Disc Check Valves operate to the principle of a free-swinging check valve. The disc is double offset to a very high degree and is opened by the upstream flow. The closing moment resulting from the weight of the disc and weight-loaded lever acts against this opening moment. This closing moment initiates closing when the flow ceases. It can be reduced within certain limits by moving the counter-weight on the lever towards the shaft. However, it must be in any case ensured that the valve disc closes even without counterpressure.

The shaft of the ERHARD Tilting-Disc Check Valves with oleohydraulic damping device protrudes on one side (key connection). The other side is closed by a blank cover. The weight-loaded lever and the oleohydr. damping device are mounted according to the figure specified by the customer. Figure arrangement to drawing **4E106000**.

Change of the already mounted ERHARD Tilting-Disc Check Valves with oleohydraulic damping device to an other figure arrangement, can – depending on the figure – only be carried out by completely changing the shafts in the body.

At the manufacturer's plant the valves have been tested for tightness and strength to DIN EN12 266.

5 Installation into the Pipeline – Mounting

Remove all packing material from the valve. Prior to installation, check the pipeline for impurities and foreign matters and clean it if necessary.

Observe direction of installation according to arrow pointing in flow direction!

It is important that all around the valve there is free access for operation and maintenance. For outdoor installation, the customer has to protect the valve against the direct effects of the weather.

During installation of the valve, the distance between the pipe flanges should exceed the valve face-to-face dimension by at least 20 mm. Thus, the raised faces will not be damaged and the gaskets can be inserted. Steel-reinforced rubber seals are recommended for use as flange gaskets (consider resistance to flow medium and temperature).

The mating pipe flanges must be plain-parallel and concentric.

Tighten the connecting bolts evenly (without distortion) and crosswise.

Operating Instructions for ERHARD Tilting-Disc Check Valves with weight-loaded lever and oleohydraulic damping device

ERHARD Tilting-Disc Check Valves shall not be installed directly upstream or downstream of pipeline components, as bends, valves, etc., as due to the short face-to-face dimension of the valve, the valve disc extends beyond the body flanges. The valve disc could otherwise collide with these components or the flow could be disturbed because the valve disc does not open or opens only partly (for DN 800 and larger also consider the stop when installing and removing the valve. A dismantling piece is required in this case. See catalogue sheet, table of dimensions, dimensions e4, e5, and e6).

Before filling the pipeline with water, check the valve for easy running: Operate the weight-loaded lever over the total travel (90°). Do not drop the weight-loaded lever.

6 Maintenance

ERHARD Tilting-Disc Check Valves are equipped with maintenance-free plain bearings. The precise elastomer seal inserted into the metallic sealing face of the valve disc is replaceable.

Precise elastomer seal and complete shaft seal are available as spare parts.

Prior to carrying out works at the valve, the pipeline section has to be made pressureless and emptied.

1. Replacing the shaft seal

to drawing **4E119 882**

- 1.1 Remove safety ring (24), key (23) and weight-loaded lever from shaft (6).
- 1.2 Loosen hexagon bolts (20) and remove straight pins (18). Remove bracket (16) together with distance piece (14).
- 1.3 Dismantle complete spacer with O-rings (11, 12, 13) by means of two screw drivers.
- 1.4 Mount new spacer with O-rings as well as distance piece, bracket and lever in reverse order.

Operating Instructions for ERHARD Tilting-Disc Check Valves with weight-loaded lever and oleohydraulic damping device

2. Replacing the valve disc seal

to drawing **4E119 882**

2.1 Remove O-ring (5)

2.2 Rub grease approved for potable water on the new endless O-ring. Slightly extend O-ring and evenly press into dove-tail groove of the valve disc.

7 Design with oleohydraulic damping device	PN10 Prod. No. 5503 ..59
	PN16 Prod. No. 5504 ..59
	PN25 Prod. No. 5505 ..59

7.1 Mode of operation

ERHARD Tilting-Disc Check Valves are equipped with oleohydraulic damping device, whenever

- a) backflow of the flow medium is admitted, i.e. the valve shall close in a retarded manner to reduce closing hammer.
- b) the valve shall open in a retarded manner under sudden acceleration of the flow medium (pump starts against the closed check valve) in order to prevent opening hammer.

The oleohydraulic damping device acts in both limit positions and keeps the disc from chattering over the whole travel. The oleohydraulic damping device is supported on a bracket flanged to the valve body. The piston rod is hinged on the weight-loaded lever which is firmly connected to the valve disc by the shaft.

When opening the valve, the disc can open up to approx. 10° before fully open position without any damping effect. On closing, the disc swings freely to approx. 15° before fully closed position without any damping being effected. Within this range, the inside diameter of the hydraulic damping device is increased so that oil can flow around the piston.

From 10° to the open position and from 15° to the closed position, there will be a damping effect. The damping times are adjustable by means of a flow control valve.

Operating Instructions for ERHARD Tilting-Disc Check Valves with weight-loaded lever and oleohydraulic damping device

The closing time is preset at the manufacturer's works considering the existing weight load, but not the backpressure acting on the valve disc and has to be readjusted to the requirements of the whole system when putting the valve into operation. Changes in the damping time are set at the rotary knob of the flow control valve. The high values of the ten-mark scale are used for quick closing, the lower values for slower closing of the valve. The times can only be set when a key is put into the lock of the rotary knob.

Attention:

When the Tilting-Disc Check Valve is equipped with mounted oleohydraulic damping device on both sides, the flow control valve of both oleohydraulic damping devices must be adjusted at the same time.

Damping time adjustment to drawing **4E121 445**

7.2 Limit values

Depending on the valve's shaft diameter and the material used for standard type valves, the max. admissible backpressure acting on the valve disc is limited as follows:

Nom. size DN	150	200	250	300	350	400	450	500	600	700	800	900	1000
Max. admiss. back pressure (bars) *	12.5	14.5	7.1	8.5	5.4	3.6	4.5	3.3	3.2	3.1	2.9	2.9	2.9

*Back pressure values are only valid if one single hydraulic damping device is mounted on the ERHARD Check Valve.
In case two hydraulic damping cylinders are mounted, twice the back pressure is permissible.

On request ERHARD Tilting-Disc Check Valves equipped with oleohydraulic damping device can also be supplied with reinforced shafts for higher backpressures. Specify back pressure when placing the order.

7.3 Maintenance (see drawing **4E106 310**)

The oleohydraulic damping device has to be checked for oil leakage at regular intervals. For refilling, open the filling screw at the cover of the damping device and fill hydraulic oil up to the lower edge of the filling hole. Then close filling screw tightly.

Use only:

Hydraulic oil, type H-LP 32 to DIN 51525
kinematic viscosity at 40°C, 32 mm²/s to DIN 51562

Operating Instructions for ERHARD Tilting-Disc Check Valves with weight-loaded lever and oleohydraulic damping device

We recommend:

The hydraulic oil should be replaced every 5 years. In case hydraulic damping devices are installed on both sides, please observe the following:

For hoses and hose pipes, follow ZH 1/74 (HVBG). Even in case of appropriate storage and permissible strain, hoses and hose pipes are subject to a natural ageing process. Thus, storage and usability periods are limited.

Therefore, hoses or hose pipes must be replaced at regular intervals, even if no defects concerning safety requirements can be detected. The period of usage should not exceed 6 years including a storage period of max. 2 years.