

Three functions automatic air valve for sewage Mod. SCF 2" - PN 16

The air valve will guarantee the proper operation of sewage lines allowing the entrance of large air quantity during pipe bursting or draining phases, the release of air pockets during working conditions and the discharge during pipe filling phases

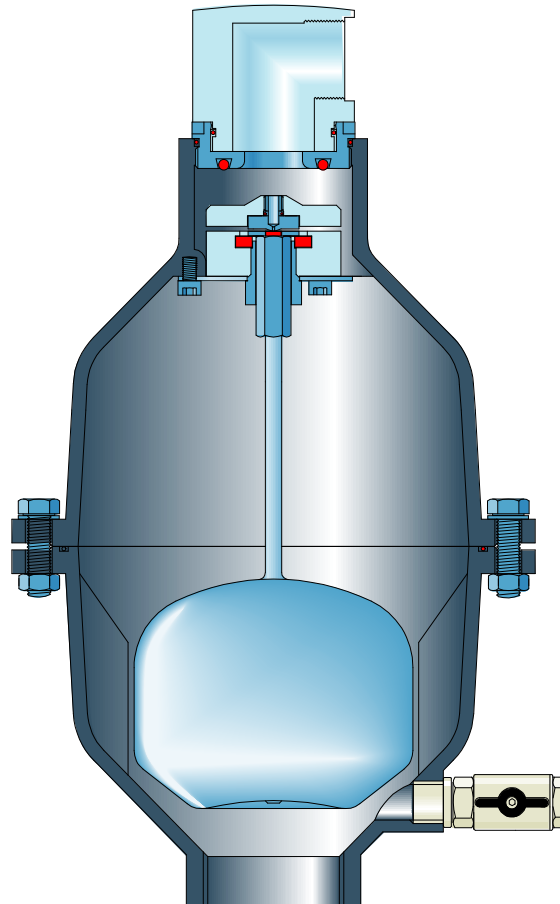

Construction and advantages

- Lower body designed with strongly sloped high walls to avoid deposit of grease and/or other material, and containing four ribs to guide the stainless steel float.
- Upper body containing the air release device which is protected against projections, during rapid filling phases by a s.s. diffuser.
- Mobile block including a large AISI 316 stainless steel float, placed on the lower body and connected through a stainless steel rod to the air release mechanism.
- Drainage valve for chamber control and draining.
- Maintenance can be easily performed from the top without removing the air valve from the pipe.
- Evacuation bend suitable for flooded environments with 1" threaded outlet.

Operating principle

1) Discharge of large volumes of air

During pipe filling it is necessary to discharge as much air as water flowing in.

1) Entrance of large volumes of air

During pipeline draining or bursting phases it is necessary to bring in as much air as the quantity of out-flowing water to avoid vacuum conditions.

3) Air release during working conditions.

During operation, an air pocket is accumulated in the upper part of the valve body, little by little it is compressed and its pressure arrives to water pressure, its volume increases pushing water downwards. Following Archimede's principle the float, no longer sustained by water thrust, will fall down to free the nozzle hole helping the release of the air pocket, while the upper disk will close the main orifice due to an internal pressure.

For air flow performances of SCF 2" please refer to the chart depicted on the next page.

Air flow performance chart.

AIR DISCHARGE DURING PIPE FILLING

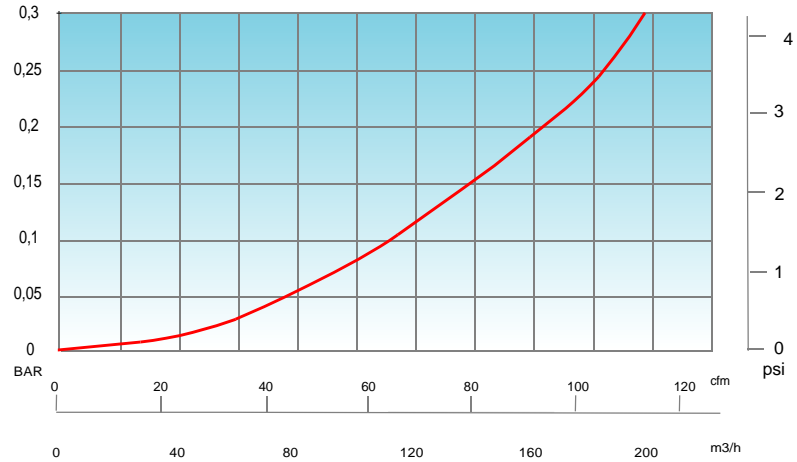

AIR ENTRANCE DURING PIPE DRAINING

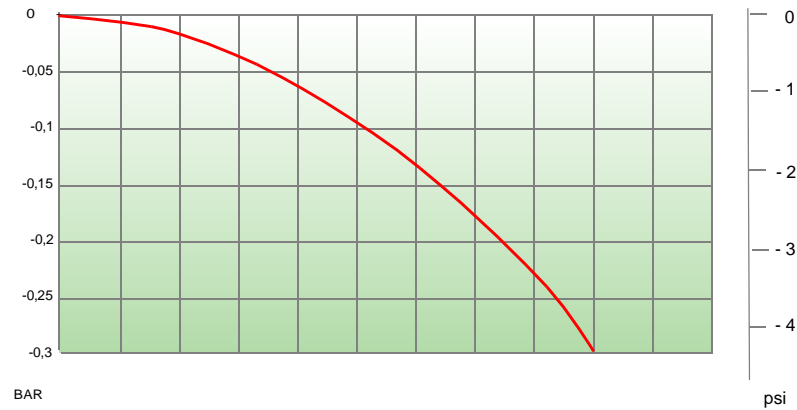

Working conditions

Waste water 70 °C/ 158 °F Max;
 Maximum pressure 16 bar/ 232 psi;
 Minimum pressure 0,35 bar/ 5.2 psi.

Technical features

Lower body and upper body entirely made in ductile cast iron, internal and external painted with epoxy powders applied using fluidized bed technology.

Obturator in polypropylene

Nozzle and gasket holder in stainless steel AISI 316

Float and rod in stainless steel AISI 316

Gaskets in NBR

Sealing seat in stainless steel AISI 304

Drainage valve in galvanized brass or stainless steel

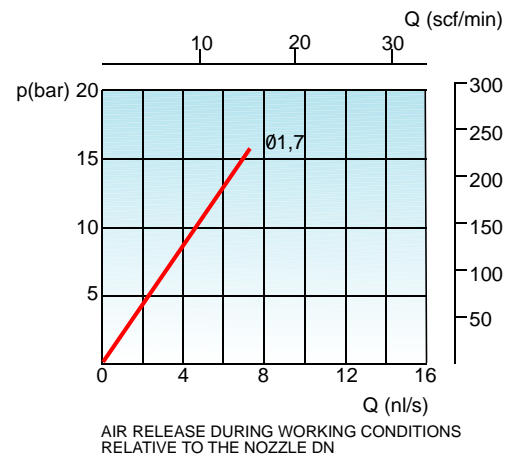

AIR RELEASE DURING WORKING CONDITIONS RELATIVE TO THE NOZZLE DN

DN/C	A	B	D	Main orifice mm ²	Nozzle mm ²	Weight Kg
2"	1"	380	137	490	1,7	10,5

