

Three functions automatic air valve for sewage Mod. SCF

SCF air valve will guarantee the proper operation of sewage lines allowing the entrance and the discharge of large volumes of air, both during pipe draining and filling operations, and the release of air pockets during working conditions.

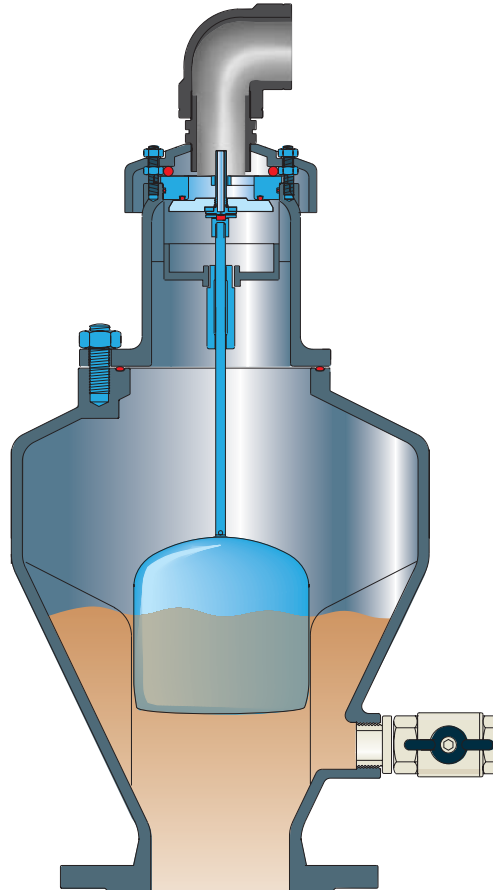

Construction and advantages

- Large lower body designed with strongly sloped high walls to avoid deposit of grease and/or other material, and containing four fusion obtained nerves to guide the stainless steel float.
- Upper body containing an air release device protection cup against projections during rapid filling phases.
- Mobile block including a large AISI 316 stainless steel float, placed on the lower body and connected through a stainless steel rod to the air release system.
- Drainage valve for chamber control and draining.
- Nozzle and gasket holder (pat. pending) wear resistant thanks to gasket compression control.
- Maintenance can be easily performed from the top without removing the air valve from the pipe.

Operating principle

1) Discharge of large volumes of air

During pipe filling it is necessary to discharge as much air as the water flowing in.

2) Entrance of large volumes of air

During pipeline draining or bursting phases it is necessary to bring in as much air as the quantity of out-flowing water to avoid vacuum conditions.

3) Air release during working conditions.

During operation, an air pocket is accumulated in the upper part of the valve's lower body, little by little it is compressed and its pressure arrives to water pressure, its volume increases pushing the water downwards. Following Archimedes's principle the float, no longer sustained by water thrust, will fall down to free the nozzle hole helping the release of the air pocket, while the upper disk will close the main orifice due to an internal pressure.

For air flow performances of SCF please refer to the chart depicted on the next page.

Air flow performance chart

AIR DISCHARGE DURING PIPE FILLING

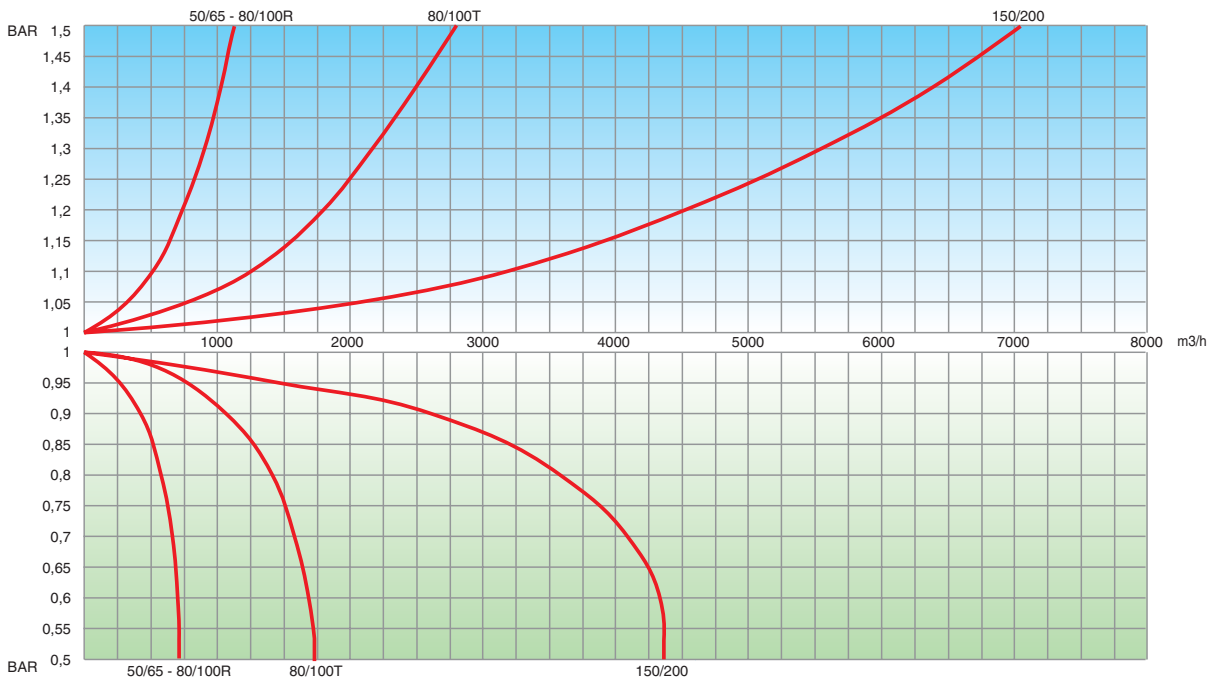

AIR INTAKE DURING PIPE DRAINING AND BURST

Working conditions

Waste water 70°C/158 °F Max;
 Maximum pressure 16 bar/ 232 psi;
 Minimum pressure 0,2 bar/ 4.35 psi.

Technical features

Lower body, upper body and cover entirely made in ductile cast iron internal and external painting with epoxy powders applied using fluidized bed technology.

Obturator in polypropylene

Nozzle and gasket holder in stainless steel AISI 316

Float and rod in stainless steel AISI 316

Nuts and bolts in stainless steel A2

Gaskets in NBR

Sealing seat in stainless steel

Drainage valve in galvanized brass or stainless steel

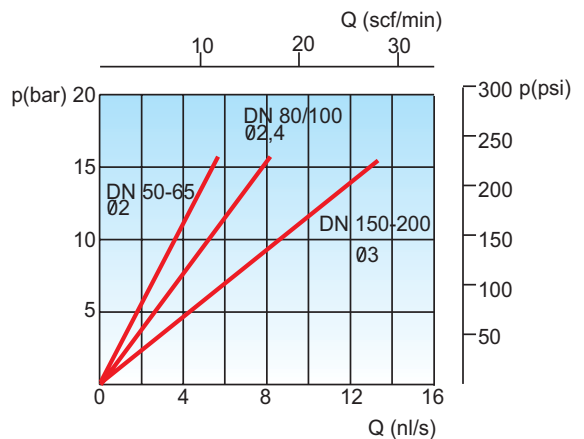

AIR RELEASE DURING WORKING CONDITIONS RELATIVE TO THE NOZZLE DN

DN	A (mm)	B (mm)	C (mm)	D (mm)	E (mm)	Weight (kg)
50/65	185	550	90	300	202	29
80/100R	220	546	110	300	208	31
80/100T	220	600	-	350	190	40
150	285	850	-	488	243	78
200	340	850	-	488	243	82

