

GESTRA Steam Systems

NRG 16-50

NRG 17-50

NRG 19-50

NRG 111-50

EN

English

Installation Instructions 818954-04

Level Electrodes

NRG 16-50, NRG 17-50, NRG 19-50, NRG 111-50

Contents

Page

Important Notes

Usage for the intended purpose.....	4
Function.....	4
Safety note.....	4

Directives and standards

EC Pressure Equipment Directive 97/23/EC.....	5
Functional Safety acc. to IEC 61508.....	5
VdTÜV Bulletin "Wasserstand 100" (= Water Level 100).....	5
ATEX (Atmosphère Explosible).....	5
UL/cUL (CSA) Approval.....	5
Note on the Declaration of Conformity / Declaration by the Manufacturer CE	5

Technical data

NRG 16-50, NRG 17-50, NRG 19-50.....	6
Scope of supply.....	7
Name plate/markings.....	8

Installation

Dimensions NRG 16-50, NRG 17-50, NRG 19-50.....	9
Dimensions NRG 111-50.....	10
Tools.....	11
NRG 16-50, NRG 17-50, NRG 19-50, NRG 111-50.....	12
NRG 16-50, NRG 17-50, NRG 19-50, NRG 111-50, step 1.....	13
NRG 16-50, NRG 17-50, NRG 19-50, NRG 111-50, step 2.....	13
Key.....	13
NRG 16-50 F, NRG 17-50 F, NRG 19-50 F, NRG 111-50 F, with aluminium terminal box.....	14
NRG 16-50 F, NRG 17-50 F, NRG 19-50 F, additional information.....	15
Key.....	15

Examples of installation

NRG 16-50, NRG 17-50, NRG 19-50.....	16
NRG 111-50.....	17
Key.....	17

Electrical connection

NRG 16-50, NRG 17-50, NRG 19-50, NRG 111-50, four-pole connector.....	18
Key	18
Connection of level electrode	19
NRG 16-50, NRG 17-50, NRG 19-50, NRG 111-50, with four-pole connector	19
NRG 16-50 F, NRG 17-50 F, NRG 19-50 F, NRG 111-50 F, with aluminium terminal box	19
Tools	19
Wiring diagram	20
Key	20

Commissioning, fault indication and troubleshooting21**Removing and disposing of the level electrode**

Removing and disposing of level electrode NRG 1..-50.....	21
Removing and disposing of level electrode NRG 1..-50F.....	21

Important Notes

Usage for the intended purpose

The level electrodes NRG 1...-50 are used in conjunction with level switch NRS 1-50 as water level limiters for steam boilers and (pressurised) hot water installations.

Water level limiters switch off the heating when the water level falls below the set minimum level (low water).

Function

When the water level falls below the low level, the level electrode is exposed and a low level alarm is triggered in the level switch NRS 1-50. This switchpoint "Low water level (LW)" is determined by the length of the electrode tip.

The electrode operation is based on the conductive measuring principle using the electrical conductivity of the water for signalling water level. The self-monitoring function ensures that an alarm will also be triggered if the electrode insulation is contaminated or has developed a leak or if there is a malfunction in the electrical connection.

The level electrode is installed inside steam boilers, vessels or inlet lines of hot-water systems. The protective tube mounted on site (see section **Examples of Installation** - pages 16, 17) ensures correct functioning.

One level electrode NRG 1...-50 can be installed together with one GESTRA level electrode, one level switch or transmitter for water level control and high level alarm in one single protection tube or level pot.

If the level electrode is installed in an isolatable level pot outside the boiler, make sure that the connecting lines are rinsed regularly. In addition, the logic unit SRL is required to monitor the purging times and the purging sequence.

If the connecting lines for steam ≥ 40 mm and water ≥ 100 mm, the installation is considered to be internal. In this case the rinsing processes do not have to be monitored.

Safety note

Water level limiters are safety accessories as defined in the Pressure Equipment Directive (PED) and must only be installed, wired and commissioned by qualified and competent staff.

Retrofitting and maintenance work must only be performed by qualified staff who - through adequate training - have achieved a recognised level of competence.



Danger

When loosening the electrode steam or hot water might escape!

This presents the risk of severe scalding all over the body!

It is therefore essential not to dismantle the electrode unless the boiler pressure is verified to be 0 bar.

The electrode becomes hot during operation.

Risk of severe burns to hands and arms.

Before carrying out installation and maintenance work make sure that the steam trap is cold.



Attention

The name plate specifies the technical features of the equipment. Do not commission or operate any item of equipment that does not bear its specific name plate.

Directives and standards

EC Pressure Equipment Directive 97/23/EC

Water level limiters are safety accessories as defined in the Pressure Equipment Directive (PED). The level electrode NRG 1...-50 in conjunction with level switch NRS 1-50 is EC type approved according to EN 12952/EN 12953. These Directives state, among other things, the requirements made on limiting systems and equipment for steam boiler plants and (pressurised) hot-water installations.

Functional Safety acc. to IEC 61508

The level electrodes NRG 1...-50 / NRG 16-36 are certified acc. to IEC 61508 only if used in combination with level switch NRS 1-50. This standard describes the functional safety of safety-related electrical/electronic/programmable electronic systems.

The equipment combination NRG 1...-50 or NRG 16-36 + NRS 1-50 corresponds to a type B sub-system with Safety Integrity Level (SIL) 3.

VdTÜV Bulletin "Wasserstand 100" (= Water Level 100)

The level electrodes NRG 1-50, NRG 1...-11 and NRG 16-36 in conjunction with the level switch NRS 1-50 are type approved according to the VdTÜV Bulletin "Water Level 100".

The VdTÜV Bulletin "Wasserstand (= Water Level) 100" specifies the requirements made on water level control and limiting equipment for boilers.

ATEX (Atmosphère Explosible)

The level electrodes NRG 1...-50, NRG 1...-11 and NRG 16-36 are simple items of electrical equipment as specified in EN 60079-11 section 5.7. According to the European Directive 94/9/EC the equipment must be equipped with approved Zener barriers if used in potentially explosive areas. Applicable in Ex zones 1, 2 (1999/92/EC). The equipment does not bear an Ex marking.

The suitability of the Zener barriers is certified in a separate document.

Note that the requirements of the IEC 61508 are not met if the NRG 1...-50, NRG 1...-11, NRG 16-36 + Zener barriers + NRS 1-50 are interconnected!

UL/cUL (CSA) Approval

The equipment meets the requirements of Directives: UL 508 and CSA C22.2 No. 14-13, Standards for Industrial Control Equipment. File E243189.

Note on the Declaration of Conformity / Declaration by the Manufacturer **CE**

For details on the conformity of our equipment according to the European Directives see our Declaration of Conformity or our Declaration of Manufacturer.

The current Declaration of Conformity / Declaration of Manufacturer are available in the Internet under www.gestra.en/documents or can be requested from us.

Technical data

NRG 16-50, NRG 17-50, NRG 19-50

Service pressure

NRG 16-50: PN 40, 32 bar at 238 °C

NRG 17-50: PN 63, 60 bar at 275 °C

NRG 19-50: PN 160, 100 bar at 311 °C

NRG 111-50: PN 320, 183 bar at 357 °C

Mechanical connection

Screwed G $\frac{3}{4}$ A to ISO 228-1 (NRG 16-50, NRG 17-50, NRG 19-50)

Screwed G 1 A to ISO 228-1 (NRG 111-50)

Materials

Screw-in body: 1.4571, X6CrNiMoTi17-12-2 (NRG 16-50, NRG 17-50, NRG 19-50)

Screw-in body: 1.4529, X1NiCrMoCuN25-20-7 (NRG 111-50)

Measuring electrode: 1.4571, X6CrNiMoTi17-12-2 (NRG 16-50, NRG 17-50, NRG 19-50)

Measuring electrode: 1.4122, X39CrMo17-1 (NRG 111-50)

Electrode tip: 1.4401, X5CrNiMo17-12-2

Electrode insulation: Gylon® (NRG 16-50, NRG 17-50, NRG 19-50)

Electrode insulation: special ceramic (NRG 111-50)

NRG 1...-50: Four-pole connector: polyamide (PA)

NRG 1...-50F: Terminal box 3.2161 G AISi8Cu3

Lengths supplied

500 mm, 1000 mm, 1500 mm, 2000 mm, 2500 mm, 3000 mm

ph value

Max. admissible: 10 (NRG 111-50)

Electrical connection

NRG 1...-50: Four-pole connector, cable glands M 16

NRG 1...-50F: Terminal box made from aluminium, cable gland M 20

Protection

IP 65 to EN 60529

Admissible ambient temperature

Max. 70 °C

Weight

Approx. 1.2 kg (without extension) (NRG 16-50, NRG 17-50, NRG 19-50)

Approx. 2.1 kg (without extension) (NRG 16-50F, NRG 17-50F, NRG 19-50F)

Approx. 1.8 kg (without extension) (NRG 111-50)

Approx. 2.7 kg (without extension) (NRG 111-50F)

Approvals

EC Prototype approval	PED Pressure Equipment Directive 97/23/EC, EN 12952-11, EN 12953-09: Requirements made on limiting equipment for boilers.
Functional Safety SIL 3	acc. to EN 61508: Functional safety of safety-related electrical/electronic/programmable electronic systems
TÜV type approval	VdTÜV Bulletin "Water Level 100": Requirements made on water level limiting & control equipment. Type approval no. TÜV · SWB / SHWS · ...-422 (see name plate)
UL/cUL (CSA) Approval	UL 508 and CSA C22.2 No. 14-13, Standards for Industrial Control Equipment. File E243189.

Scope of supply

NRG 16-5

- 1 Level electrode NRG 16-50, PN 40
- 1 Joint ring 27 x 32, form D, DIN 7603, 1.4301, bright annealed
- 1 Washer with set screw (measuring surface extension) (optional)
- 1 Retaining ring (optional)
- 1 Installation manual

NRG 17-50

- 1 Level electrode NRG 17-50, PN 63
- 1 Joint ring 27 x 32, form D, DIN 7603, 1.4301, bright annealed
- 1 Washer with set screw (measuring surface extension) (optional)
- 1 Retaining ring (optional)
- 1 Installation manual







NRG 19-50

- 1 Level electrode NRG 19-50, PN 160
- 1 Joint ring 27 x 32, form D, DIN 7603, 1.4301, bright annealed
- 1 Washer with set screw (measuring surface extension) (optional)
- 1 Retaining ring (optional)
- 1 Installation manual

NRG 111-50





- 1 Level electrode NRG 111-50, PN 320
- 1 Joint ring 33 x 39, form D, DIN 7603, 1.4301, bright annealed
- 1 Washer with set screw (measuring surface extension) (optional)
- 1 Retaining ring (optional)
- 1 Installation manual





Name plate/markings

Equipment designation		Safety note	
NRG 16-50 		 Betriebsanleitung beachten See installation instructions Voir instructions de montage	
PN 40 G 3/4 1.4571 IP 65		TÜV . SWB . 09-422	
 32 bar (464psi) 238°C (460°F) T amb = 70°C (158 °F)			
GESTRA AG • D-28215 Bremen		0525	
Manufacturer		Serial number	
NRG 111-50 		 Betriebsanleitung beachten See installation instructions Voir instructions de montage	
180 bar (2609psi) 357°C (675°F) T amb = 70°C (158 °F)		TÜV . SWB/SHWS . 09-422	
GESTRA AG • D-28215 Bremen		0525	

— Disposal note
— Pressure rating, thread type,
material number, type approval number
— CE Marking

Fig. 1

 Betriebsanleitung beachten See installation instructions Voir instructions de montage Hier öffnen Open here Ouvrir ici	
NRG 16 - 50 F	PN 40 <input type="checkbox"/>
NRG 17 - 50 F	PN 63 <input type="checkbox"/>
NRG 19 - 50 F	PN160 <input type="checkbox"/>
G 3/4 1.4571 IP65	
 32 bar (464psi) 238°C (460°F)	<input type="checkbox"/>
60 bar (870psi) 275°C (527°F)	<input type="checkbox"/>
100 bar (1450psi) 311°C (592°F)	<input type="checkbox"/>
 Tamb = 70°C (158°F)	
TÜV . SWB . 09-422	
GESTRA AG Münchener Str. 77 D-28215 Bremen	

 Betriebsanleitung beachten See installation instructions Voir instructions de montage Hier öffnen Open here Ouvrir ici	
NRG 111 - 50 F	
G 1 1.4529 IP65	
 180 bar (2609psi) 357°C (675°F)	
 Tamb = 70°C (158 °F)	
TÜV . SWB . 09-422	
GESTRA AG Münchener Str. 77 D-28215 Bremen	
_____ _____	

— Safety note
— Equipment designation
— Pressure rating, thread type,
material number
— Pressure/temperature rating
— CE Marking, type approval
— Disposal note
— Manufacturer
— Serial number

Fig. 2

Fig. 3

Installation

Dimensions NRG 16-50, NRG 17-50, NRG 19-50

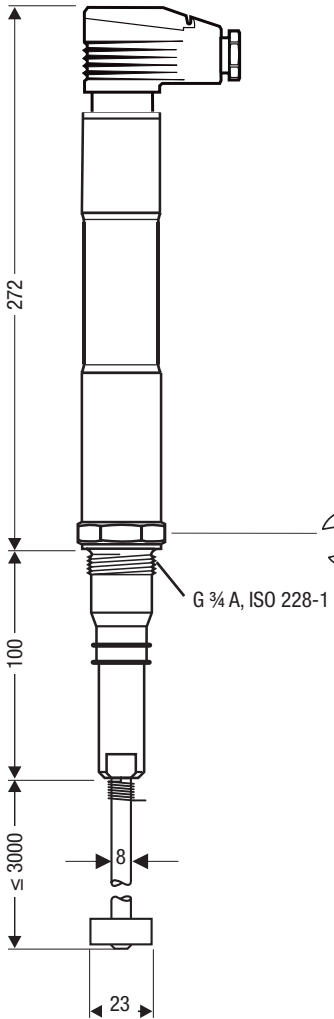

Fig. 4
NRG 16-50, NRG 17-50, NRG 19-50
with four-pole connector and measuring surface
extension

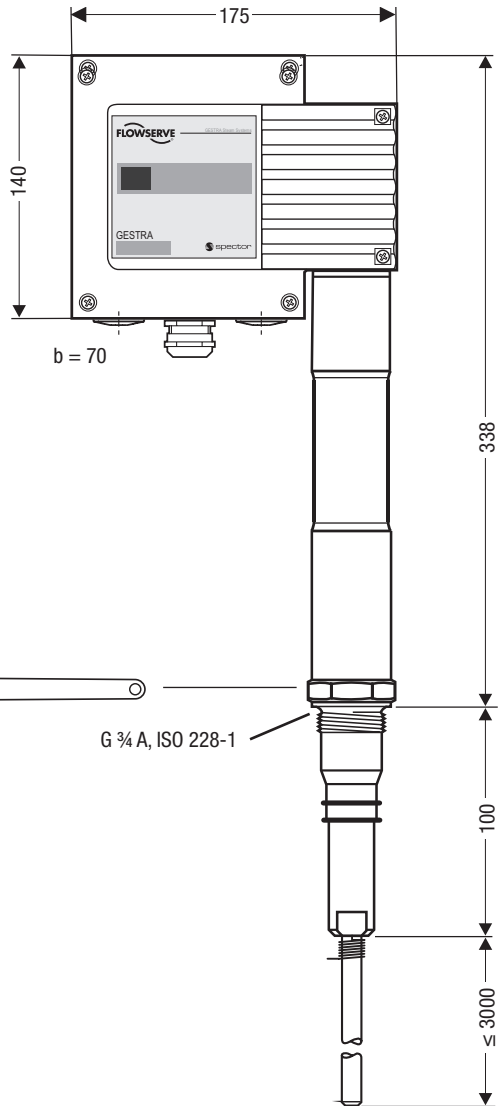

Fig. 5
NRG 16-50F, NRG 17-50F, NRG 19-50F
with aluminium terminal box



Note

- **One** level electrode NRG 1...-50 can be installed together with one GESTRA level electrode, one level switch or transmitter for water level control or high level alarm in one single protection tube or level pot (inside diameter 100 mm). **Fig. 17.** If the electrode NRG 1...-50 is installed inside the vessel, it must be at least 40 mm away from the upper vent hole.
- The installation of two water-level limiting electrodes NRG 1...-50 in one single standpipe is not allowed.
- For the approval of the boiler standpipe the relevant regulations must be considered.
- Refer to pages 16 – 17 for typical installation examples.
- The angle of inclination of the electrode must not exceed 45°, with the length of the electrode rod being limited to 1000 mm. **Fig. 16, 20**
- If used in combination with level switch NRS 1-50 with a response sensitivity of 0.5 $\mu\text{S}/\text{cm}$ please use a measuring surface extension.
- For outdoor installations please use level electrode NRG 1...-50 F. Level electrodes with this suffix (F) feature a terminal box made from aluminium.



Attention

- The seating surfaces of the standpipe or the flange provided on the vessel must be accurately machined, see **Fig. 12.**
- If the level electrode NRG 111-50 is to be installed in a flanged standpipe DN 50 use only the GESTRA hat flange. **Fig. 11**
- Do not bend electrode tip when mounting.
- Use only the joint rings supplied with the electrode.
NRG 16-50, NRG 17-50, NRG 19-50: 27 x 32, form D, DIN 7603, 1.4301
NRG 111-50: 33 x 39, form D, DIN 7603, 1.4301
- Do not lag electrode body above the hexagonal section.
- Do not insulate electrode thread with hemp or PTFE tape!
- Do not apply conductive paste or grease to the electrode thread!
- Make sure that the air distance between the electrode rod and earth (flange, vessel wall) is not less than 14 mm. **Fig. 11, Fig. 15-21**
- Observe the minimum distances for the installation of the electrode!

Tools

- Open-end spanner A. F. 13, DIN 3110, ISO 3318
- Open-end spanner A. F. 19, DIN 3110, ISO 3318
- Open-end spanner A. F. 41, DIN 3110, ISO 3318
- Scriber
- Hacksaw
- Flat file, medium cut, DIN 7261, form A

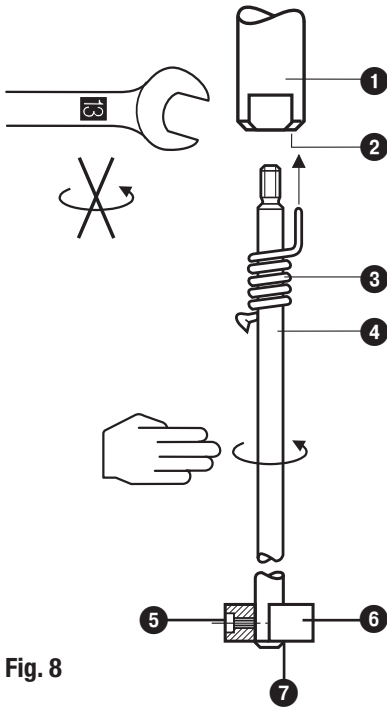

Fig. 8

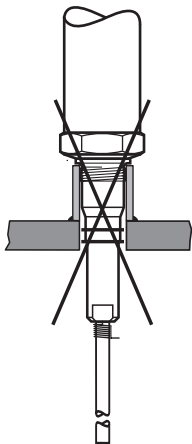

Fig. 10

NRG 16-50
NRG 17-50
NRG 19-50

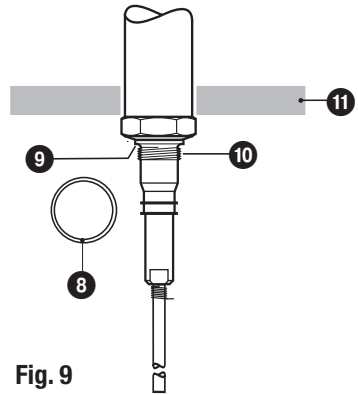

Fig. 9

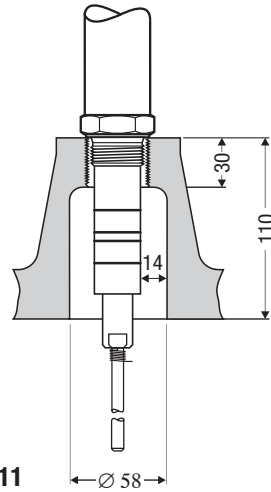

Fig. 11

NRG 111-50

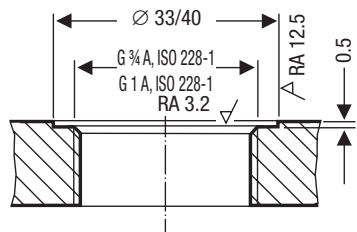

Fig. 12

NRG 16-50, NRG 17-50, NRG 19-50, NRG 111-50, step 1

1. Screw electrode tip ④ into measuring electrode ①. **Fig. 8**
2. Carefully determine required measuring length of electrode.
3. Mark length of electrode tip ④.
4. Unscrew electrode tip ④ from measuring electrode ① and cut tip.
5. After visual inspection screw electrode tip ④ into measuring electrode ①. Slide spring ③ along electrode tip 4 so that its end completely enters the small hole ②.
6. Mounting the measuring surface extension: Fit disk ⑥ to electrode tip, making sure that the electrode tip protrudes 2 mm beyond the bottom of the surface extension disk. Fix the disk in this position with the set screw ⑤. Push supplied lock washer ⑦ from below over electrode tip and against surface extension disk ⑥.

NRG 16-50, NRG 17-50, NRG 19-50, NRG 111-50, step 2

7. Check seating surfaces. **Fig. 12**
8. Place supplied joint ring ⑧ onto seating surface of the threaded standpipe or flange. **Fig. 9**
9. Apply a light smear of heat resistant silicone grease (e.g. WINIX® 2150) to electrode thread ⑦.
10. Screw level electrode into threads or flange provided on vessel and tighten with a 41 mm open-end spanner. The torque required when **cold is 160 Nm**.

Key

- | | |
|--------------------------------------|---|
| ① Measuring electrode | ⑧ NRG 1...-50: Joint ring 27 x 32, form D, DIN 7603, 1.4301, bright annealed |
| ② Bore | NRG 111-50: Joint ring 33 x 39, form D, DIN 7603, 1.4301, bright annealed |
| ③ Spring | |
| ④ Electrode tip | ⑨ Seating surface |
| ⑤ Set screw | ⑩ Electrode thread |
| ⑥ Disk (measuring surface extension) | ⑪ Thermal insulation, provided on site, d = 20 mm (outside of thermal insulation of steam boiler) |
| ⑦ Retaining ring | |

NRG 16-50 F, NRG 17-50 F, NRG 19-50 F, additional information

If one level electrode NRG 1...-50 is installed together with one level electrode, one level switch or transmitter (with aluminium terminal box) in a single protection tube or level pot, please observe the following:

1. Mount the first equipment as specified in the pertinent installation manual.

When installing level electrode NRG 1...-50 F, please observe the following instructions:

1. Loosen screws ⑫ and remove housing cover ⑭. **Fig. 13.** The arrow on the name plate points towards this cover.

2. Remove cable lugs from terminal lugs. **Fig. 14**

3. Loosen nut ⑮ with 19 mm open-end spanner but do not remove! **Fig. 14**

4. Screw in level electrode as described in step 2, items 7 – 10.

5. Turn electrode terminal box into desired direction (+/-180°).

The terminal box can be turned through +/-180°.

6. Tighten nut ⑮ with a torque of **25 Nm**.

7. Plug cable lugs onto terminal lugs.

5. Mount housing cover ⑭ and tighten screws ⑫.

Key

- ⑫ Housing screws M 4
- ⑬ Cable gland M 20 x 1.5
- ⑭ Housing cover
- ⑮ Nut
- ⑯ Terminal strip

Examples of installation

NRG 16-50, NRG 17-50, NRG 19-50

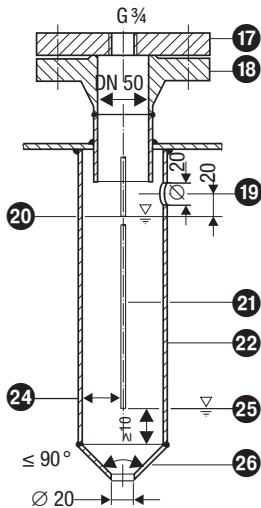

Fig. 15 Protection tube (provided on site) if electrode is used as internal water-level limiter

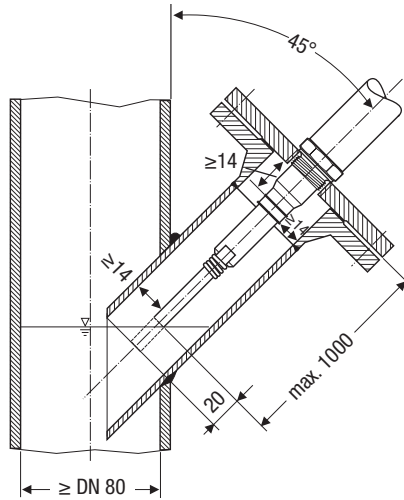

Fig. 16 Inclined installation, e. g. in ascending inlet lines of hot-water installations or vessels

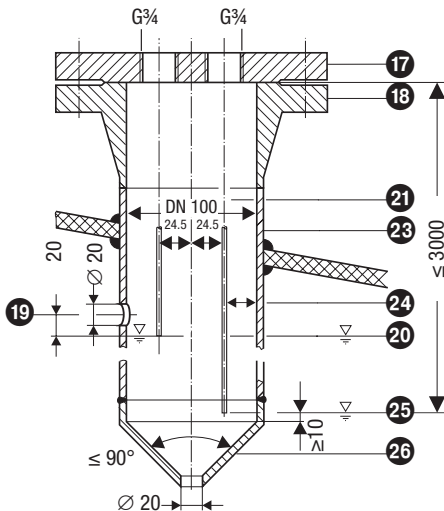

Fig. 17 Protection tube (provided on site) if electrode is used as internal water level-limiter combined with water level control or high water level alarm

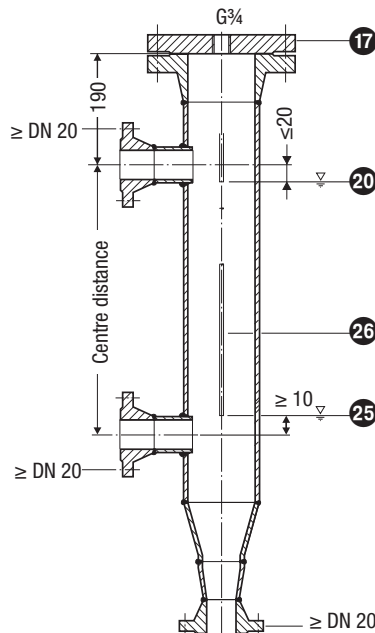

Fig. 18 Level pot \geq DN 80 if electrode is used as external water level limiter

Examples of Installation - continued -

NRG 111-50

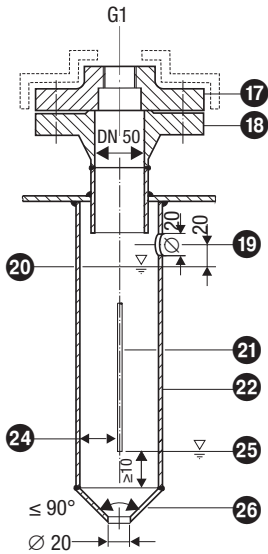

Fig. 19 Protection tube (provided on site) if electrode is used as internal water-level limiter

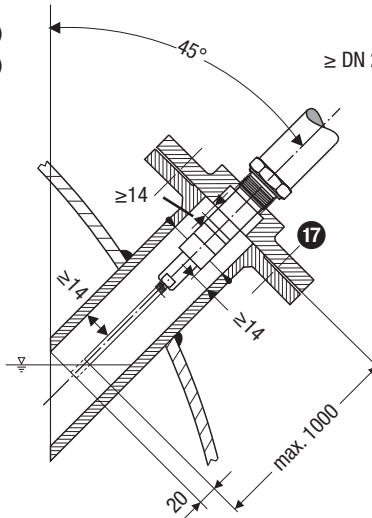

Fig. 20 Inclined installation, e.g. in steam boilers

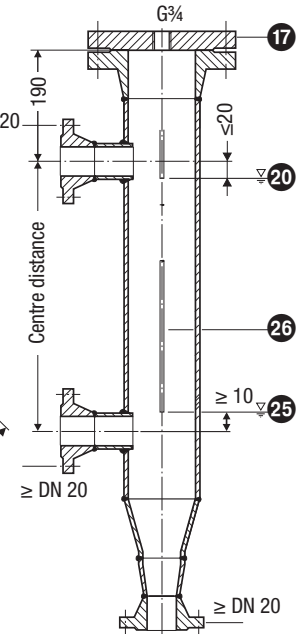

Fig. 21 Level pot \geq DN 80 if electrode is used as external water level limiter

Key

- 17** Flange PN 40, PN 63, PN 160, DN 50, DIN EN 1092-01 (for one electrode)
Flange PN 40, PN 63, PN 160, DN 100, DIN EN 1092-01 (for two electrodes)
GESTRA hat flange PN 320, DN 50, DIN EN 1092-01 (NRG 111-50)
- 18** For the approval of the boiler standpipe with connecting flange the relevant regulations must be considered.
- 22** Vent hole Provide vent hole as close to the boiler wall as possible!
- 20** High water HW
- 21** Electrode tip $d = 8$ mm
- 22** Protection tube DN 80 (in France according to AFAQ \geq DN 100)
- 23** Protection tube DN 100
- 24** Electrode distance ≥ 14 mm (air gap and creepage distance)
- 25** Low water LW
- 26** Reducer DIN 2616-2, K-88.9 x 3.2-42.4 x 2.6 W / DIN 2616-2, K-114.3 x 3.6-48.3 x 2.9 W

Electrical connection

NRG 16-50, NRG 17-50, NRG 19-50, NRG 111-50, four-pole connector

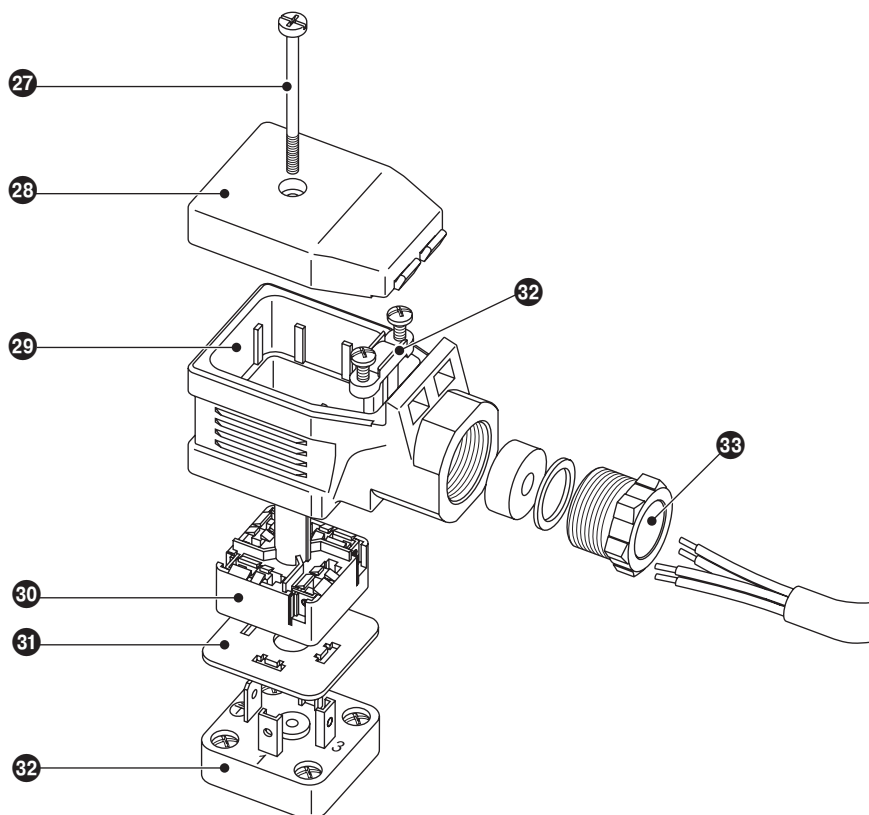

Fig. 22

Key

- | | | | |
|----|----------------------------|----|----------------------------------|
| 27 | Screw M 4 | 31 | Insulating plate |
| 28 | Cover | 32 | Contact plate of level electrode |
| 29 | Upper part of terminal box | 33 | Cable strain relief |
| 30 | Connecting plate | 34 | Cable gland M 16 (PG 9) |

Connection of level electrode

To connect the level electrode(s) please use:

- For the level switch NRS 1-50 with a response sensitivity of 10 μS :
Multi-core screened control cable, min. conductor size 0.5 mm², e. g. LiYCY 4 x 0.5 mm², max. length 100 m.
- For the level switch NRS 1-50 with a response sensitivity of 0.5 μS :
Multi-core double-screened low-capacitance data cable, min. conductor size 0.5 mm²,
Li2YCY PiMF 2 x 2 x 0.5 mm², max. length 30 m.

Wire terminal strip in accordance with the wiring diagram. **Fig. 23.** Wire the screens to terminals 5 and 13 and to the central earthing point (**CEP**) in the control cabinet.

NRG 16-50, NRG 17-50, NRG 19-50, NRG 111-50, with four-pole connector

1. Loosen screw 27. **Fig. 22**
2. Remove upper part 29 of the terminal box from the level electrode but leave insulating plate 31 on contact plate 32.
3. Remove cover 28.
4. Press connecting plate 30 out of the upper part of the terminal box 29.
The upper part of the terminal box can be turned in steps of 90°.
5. Detach cable gland 34 and cable clamp 33 from the upper part of the terminal box 29.
6. Run cable through cable gland 34 and upper part of the terminal box 29 and wire terminals of the connecting plate 30 in accordance with wiring diagram.
7. Press connecting plate 30 into the upper part of the terminal box and align cable.
8. Fix cable with cable strain relief 33 and cable gland 34 firmly into position.
9. Replace cover 28 and insert screw 27.
10. Put upper part of the terminal box onto the level electrode and fix it with screw 27.

NRG 16-50 F, NRG 17-50 F, NRG 19-50 F, NRG 111-50 F, with aluminium terminal box

1. Loosen screws 12 and remove housing cover 14. **Fig. 13, 14**
2. Loosen cable gland 13. Pull cable through cable entry.
3. Remove terminal strip 16 from board.
4. Connect terminal strip according to the wiring diagram.
5. Attach terminal strip.
6. Tighten the cable gland in order to seal the cable entry. Use the supplied sealing plug to seal off the unused cable entry and tighten the cable gland.
7. Mount housing cover 14 and tighten screws 12.

Tools

- Screwdriver, size 1
- Screwdriver, size 2.5, completely insulated according to DIN VDE 0680-1
- Open-end spanner A.F. 18 (19) mm

Wiring diagram

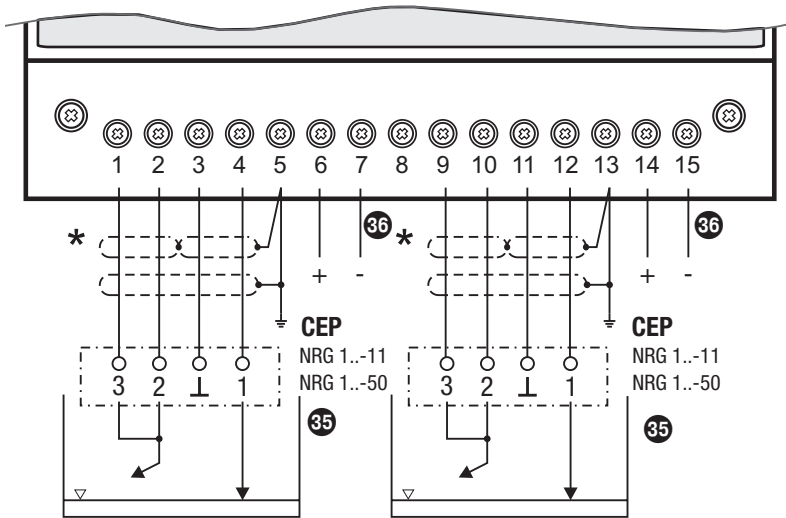

Fig. 23

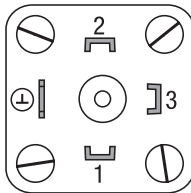

Fig. 24 Wiring of level electrode with four-pole connector

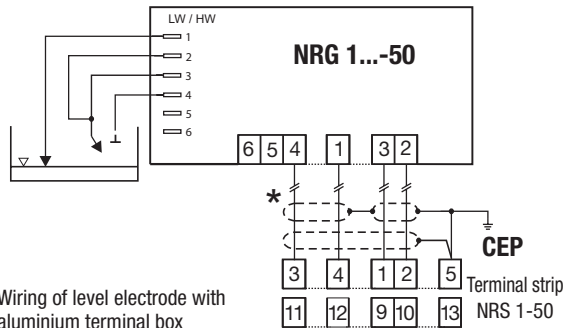

Fig. 25 Wiring of level electrode with aluminium terminal box

* NRS 1-50 with response sensitivity 0.5 $\mu\text{S}/\text{cm}$: Connect the two internal screens to terminals 5 and 13 and the **CEP**.

Key

- 35** Level electrode NRG 1...-50, NRG 1...-11
- 36** Stand-by input 1 / 2, 24 VDC, for connecting logic unit SRL
- CEP** Central earthing point in control cabinet

Commissioning, fault indication and troubleshooting

For additional information on commissioning procedures and troubleshooting refer to the installation manual of the level switch NRS 1-50.

Removing and disposing of the level electrode



Danger

When loosening the electrode steam or hot water might escape!

This presents the risk of severe scalding all over the body!

It is therefore essential not to dismantle the electrode unless the boiler pressure is verified to be 0 bar.

The electrode becomes hot during operation.

Risk of severe burns to hands and arms.

Before carrying out installation and maintenance work make sure that the steam trap is cold.

Removing and disposing of level electrode NRG 1..-50

1. Loosen screw **27**. **Fig. 22**
2. Detach upper part of the terminal box **29** from the level electrode.
3. Before removing the equipment make sure that it is neither hot nor under pressure.

For the disposal of the equipment observe the pertinent legal regulations concerning waste disposal.

Removing and disposing of level electrode NRG 1..-50F

1. Loosen screws **12** and remove housing cover **14**. **Fig. 13, 14**
2. Unplug connecting cables from terminal strip and pull cables out of the cable gland.
3. Before removing the equipment make sure that it is neither hot nor under pressure.

For the disposal of the equipment observe the pertinent legal regulations concerning waste disposal.

If faults occur that are not listed above or cannot be corrected, please contact our service centre or authorized agency in your country.



GESTRA

Agencies all over the world:

www.gestra.de

Great Britain

Flowserve GB Limited

Abex Road
Newbury, Berkshire RG14 5EY
Tel. 0044 16 35 / 46 99 90
Fax 0044 16 35 / 3 60 34
E-Mail gestraukinfo@flowserve.com
Web www.flowserve.com

Singapore

Flowserve Pte. Ltd.

12 Tuas Avenue 20
Singapore 63882
Tel. 0065 / 68 79 89 00
Fax 0065 / 68 62 49 40
E-Mail fcd_gestra_singapore@flowserve.com
Web www.gestra.com

South Africa

Flowserve SA (Pty) Ltd.

Unit No. 1
Director Road
Spartan Extension 2
Kempton Park 1613
Tel. 0027 11 / 9 23 73 00
Fax 0027 11 / 9 74 64 20
E-Mail tvniekerk@flowserve.com
Web www.flowserve.com

USA

Flowserve GESTRA U.S.

2341 Ampere Drive
Louisville, KY 40299
Tel. 001 502 / 267-22 05
Fax 001 502 / 266-53 97
E-Mail fcd-gestra-usa@flowserve.com

GESTRA AG

P.O.Box 10 54 60, D-28054 Bremen
Münchener Str. 77, D-28215 Bremen
Tel. 0049 (0) 421 / 35 03 - 0
Fax 0049 (0) 421 / 35 03 - 393
E-Mail gestra.ag@flowserve.com
Web www.gestra.de

