



FLOWSERVE

GESTRA

GESTRA Steam Systems

NRGT 26-1

NRGT 26-1S

EN
English

Installation & Operating Instructions
810213-10

Level Transmitter
NRGT 26-1, NRGT 26-1S

Contents

Page

Important notes

Usage for the intended purpose.....	4
Function.....	4
Safety note.....	4

Directives and standards

VdTÜV Bulletin "Water Monitoring 100".....	5
Approvals for Marine Applications.....	5
LV (Low Voltage) Directive and EMC (Electromagnetic Compatibility).....	5
ATEX (Atmosphère Explosible).....	5
UL/cUL (CSA) Approval.....	5
Note on the Declaration of Conformity / Declaration by the Manufacturer CE	5

Technical data

NRGT 26-1, NRGT 26-1S.....	6
Scope of supply.....	7
Name plate/markings.....	8

Installation

Dimensions NRGT 26-1, NRGT 26-1S.....	10
NRGT 26-1.....	11
NRGT 26-1S.....	11
Key.....	11
Tools.....	11

Examples of installation

NRGT 26-1.....	12
Key.....	13

Electrical connection

NRGT 26-1, NRGT 26-1S.....	14
Connection of level transmitter.....	15
Connecting the NRGT 26-1, NRGT 26-1S.....	15
Key.....	15
Tools.....	15
Wiring diagram for level transmitter NRGT 26-1, NRGT 26-1S.....	16
Connecting level transmitter NRGT 26-.. with supply voltage 24 V AC/DC.....	16
Connecting level transmitter NRGT 26-.. with supply voltage 115 / 230 V AC.....	16
Actual value output.....	16

Basic settings

Factory setting NRGT 26-1	17
Factory setting NRGT 26-1S	17
Establishing active measuring range (control range)	17

Commissioning procedure

Applying supply voltage.....	18
Adjusting lower end of measuring range	18
Adjusting upper end of measuring range	18

Troubleshooting

Indication, diagnosis and remedy	19
Replacing electronic module	20

Maintenance

Safety note.....	21
Cleaning the electrode rod	21

Removing and disposing of the level transmitter

Removing and disposing of level transmitter NRGT 26-1, NRGT 26-1S	21
---	----

Important notes

Usage for the intended purpose

The level transmitters NRG 26-1 and NRG 26-1S are used for continuous level monitoring in steam boilers and (pressurized) hot-water installations or in condensate and feedwater tanks.

In conjunction with the level switch NRS 2-... and the level controller NRR 2-... the transmitter can be used as water level controller with MIN/MAX alarm.

The level transmitter is designed for use in conjunction with the following level switches/controllers: NRS 2-50, NRS 2-51, NRR 2-50, NRR 2-51, NRR 2-52 and NRR 2-53.

The level transmitter can be used in electrically conductive and non-conductive fluids.

Function

The **level transmitter NRG 26-1** is a compact-type system consisting of a level measuring electrode and an electronic module integrated in the terminal box.

The level transmitter NRG 26-1 works according to the capacitance measurement principle and translates the level changes into a level-dependent current signal of 4-20 mA, with the length of the electrode rod determining the measuring range.

The level transmitter is installed inside steam boilers, vessels or in an external level pot. If the electrode is installed inside the boiler or vessel, a protection tube provided on side ensures correct functioning (see section **Examples of installation** (page 12).

The level transmitter can be installed together with one GESTRA level electrode for water level limiting or for high-level alarm in a single protection tube or an external level pot.

Safety note

The equipment must only be installed, wired and commissioned by qualified and competent staff.

Retrofitting and maintenance work must only be performed by qualified staff who - through adequate training - have achieved a recognised level of competence.



Danger

When loosening the level transmitter steam or hot water might escape!

This presents the risk of severe scalding all over the body!

It is therefore essential not to dismantle the level transmitter unless the boiler pressure is verified to be 0 bar.

The level transmitter becomes hot during operation.

Risk of severe burns to hands and arms.

Before carrying out installation and maintenance work make sure that the equipment is cold.

The terminal strip of the level transmitter is live during operation.

This presents the danger of electric shock!

Cut off power supply before mounting or removing the housing cover!



Attention

The name plate specifies the technical features of the equipment. Do not commission or operate any item of equipment that does not bear its specific name plate.

Directives and standards

VdTÜV Bulletin "Water Monitoring 100"

The level transmitter NRGT 26-1 is type approved acc. to VdTÜV Bulletin "Water Level 100" if used in combination with the following level switches / controllers: NRS 2-50, NRS 2-51, NRR 2-50, NRR 2-51, NRR 2-52 and NRR 2-53.

The VdTÜV Bulletin "Wasserstand (=Water Level) 100" specifies the requirements made on water level control and limiting equipment for boilers.

Approvals for Marine Applications

The level transmitter NRGT 26-1S is approved for marine applications.

LV (Low Voltage) Directive and EMC (Electromagnetic Compatibility)

The level transmitter NRGT 26-1 meets the requirements of the Low Voltage Directive 2006/95/EC and the EMC Directive 2004/108/EC.

ATEX (Atmosphère Explosible)

According to the European Directive 94/9/EC the equipment must **not** be used in explosion risk areas.

UL/cUL (CSA) Approval

The equipment meets the requirements of Directives: UL 508 and CSA C22.2 No. 14-13, Standards for Industrial Control Equipment. File E243189.

Note on the Declaration of Conformity / Declaration by the Manufacturer C€

For details on the conformity of our equipment according to the European Directives see our Declaration of Conformity or our Declaration of Manufacturer.

The current Declaration of Conformity and Declaration of Manufacturer are available in the Internet under www.gestra.com -> documents or can be requested from us.

Technical data

NRGT 26-1, NRGT 26-1S

Service pressure

PN 40, 32 bar at 238°C

Mechanical connection

NRGT 26-1: Screwed G $\frac{3}{4}$ A, ISO 228

NRGT 26-1S: Flange DN 50, PN 40, DIN EN 1092-01

Materials

Screw-in body: 1.4571, X6CrNiMoTi17-12-2

Electrode rod insulation: PTFE

Terminal box: 3.2161 G AISi8Cu3

NRGT 26-1S: Flange 1.0460 P250GH

NRGT 26-1S: Spacer disc: PTFE

NRGT 26-1

Length of installation at 238°C	373	477	583	688	794	899	1004	1110
Measuring range	300	400	500	600	700	800	900	1000

Length of installation at 238°C	1214	1319	1423	1528	1636	2156
Measuring range	1100	1200	1300	1400	1500	2000

NRGT 26-1S

Length of installation at 238°C	316	420	526	631	737	842	947	1053
Measuring range	275	420	526	575	675	737	875	975

Length of installation at 238°C	1157	1262	1366	1471	1579	2099
Measuring range	1075	1175	1275	1375	1475	1975

Weight

NRGT 26-1: approx. 1.8 kg

NRGT 26-1S: approx. 8.0 kg

Electronic module

Supply voltage

24 V AC/DC

AC +/- 20%

DC +10 / -45%

115 V +/- 10%, 50/60 Hz (option)

230 V +/- 10 %, 50/60 Hz (option)

Power consumption

3 VA at 24 V DC

5 VA at 24, 115, 230 V AC

Technical data - continued -

NRGT 26-1, NRGT 26-1S - continued -

Fuse

external slow-blow 0.5 A
internal thermal fuse $T_{\max} = 102^{\circ}\text{C}$

Sensitivity of response

Range 1: Water $\geq 20 \mu\text{S}/\text{cm}$
Range 2: Water $\geq 0.5 \mu\text{S}/\text{cm}$
Range 3: Fuel oil EL ϵ_r 2,3

Output

Actual value 4 – 20 mA, level proportional. Electrically insulated, max. load 500 Ω

Indicators and adjusters

2 red LEDs for signalling "Level 0 %" or "Level 100" within the measuring range
1 green LED for signalling "Level between 0 % and 100 %" of measuring range
1 code switch for setting the measuring range
2 adjustable resistors for small-percentage adjustment of the measuring range
2 terminal lugs for voltage measurement

Electrical connection

2 cable glands with integral cable clamp M20 x 1.5
Screw-type terminal strip with 2 and 3 terminals, detachable, conductor size 1.5 mm²

Protection

IP 65 to DIN EN 60529

Max. admissible ambient temperature

Max. 70 °C

Storage and transport temperature

– 40 to + 80 °C

Approvals:

TÜV certificate	VdTÜV Bulletin "Water Level 100" Requirements made on water level limiting & control equipment. Type approval no. TÜV · WR · XX-391, XX-425, XX-426, XX-427 (see name plate)
UL/cUL (CSA) Approval	The equipment meets the requirements of Directives: UL 508 and CSA C22.2 No. 14-13, Standards for Industrial Control Equipment. File E243189.
Marine applications	DNV A-13857, KR HMB 06190-MS002, NK TA11016M, BV 10617/CO CCS HBT 0742 1062-1, RINA ELE 407609CS, GL 992499-96 HH; LR 98/20074 (E2)

Scope of supply

NRGT 26-1

1 Level transmitter NRGT 26-1
1 Joint ring 27 x 32, form D, DIN 7603, 1.4301, bright annealed
1 Installation manual

NRGT 26-1S (for marine applications)

1 Level transmitter NRGT 26-1S with flange DN 50, PN 40, DIN EN 1092-01
1 Installation manual

Name plate/markings









	Vor Öffnen des Deckels Gerät freischalten! Betriebsanleitung beachten	
	Before removing cover isolate from power supplies See installation instructions	Safety note
	Avant d'ouvrir le couvercle déconnecter complètement l'appareil Voir instructions de montage	
NRGT 26 - 1 PN 40 <input type="checkbox"/>		Equipment designation, pressure rating
NRGT 26 - 1s PN 40 <input type="checkbox"/>		
G 3/4	1.4571	End connection, material number
DN 50	1.4571/1.0460	
	P _{max} T _{max}	32 bar (464psi) 238°C (460°F)
	T _{amb} 70°C (158°F)	IP 65
24 V <input type="checkbox"/>	115 V <input type="checkbox"/>	230 V <input type="checkbox"/>
AC/DC 3VA	50 / 60 Hz	5VA
H= _____ mm		Measuring range
4 - 20 mA / 500		Actual value output
TÜV · WR · XX-391, -425, -426, -427		Type approval no.
	99249-96 HH	
Manufacturer	GESTRA AG Münchener Str. 77 D-28215 Bremen	
		Disposal note

Fig. 1

Installation



Note

- The level transmitter NRGT 26-1 can be installed together with one GESTRA level electrode for water level limiting or for high-level alarm in a single protection tube or external level pot (inside diameter 100 mm). **Fig. 5 - 8**. If the level limiting electrode is installed inside the vessel, it must be at least 40 mm away from the upper vent hole.
- For the approval of the boiler standpipe the relevant regulations must be considered.
- Refer to pages 12 and 13 for typical installation examples.
- The angle of inclination of the electrode must not exceed 45°, with the length of the electrode being limited to 688 mm. **Fig. 9**



Attention

- The seating surfaces of the standpipe or the flange provided on the vessel must be accurately machined, see **Fig. 4**.
- Do not bend electrode tip when mounting.
- Do not subject electrode to physical shocks.
- Use only the supplied joint ring. NRGT 26-1: 27 x 32, form D, DIN 7603, 1.4301, bright annealed
- Do not lag transmitter body above the hexagonal section.
- Do not insulate transmitter thread with hemp or PTFE tape!
- Do not apply conductive paste or grease to the transmitter thread!
- Observe the minimum withdrawal distance when installing the transmitter!
- Observe the specified tightening torque.
- Do not cut the electrode rod.

Dimensions NRG 26-1, NRG 26-1S

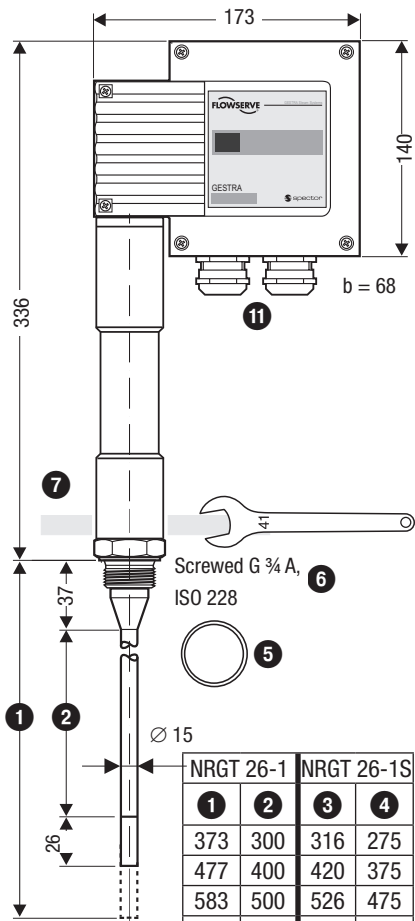

Fig. 2
NRG 26-1

NRGT 26-1		NRGT 26-1S	
1	2	3	4
373	300	316	275
477	400	420	375
583	500	526	475
688	600	631	575
794	700	737	675
899	800	842	775
1004	900	947	875
1110	1000	1053	975
1214	1100	1157	1075
1319	1200	1262	1175
1423	1300	1366	1275
1528	1400	1471	1375
1636	1500	1579	1475
2156	2000	2099	1975

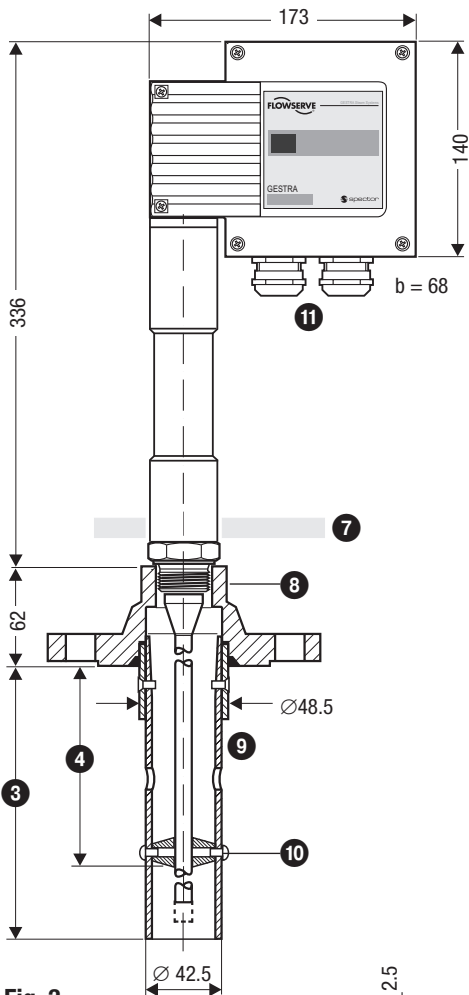

Fig. 3
NRG 26-1S

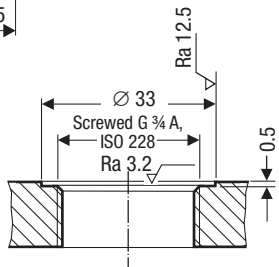

Fig. 4

Installation - continued -

NRGT 26-1

1. Check seating surfaces. **Fig. 4**
2. Place supplied joint ring **5** onto seating surface of the threaded standpipe or flange. **Fig. 4**
3. Apply a light smear of heat resistant silicone grease (e.g. WINIX® 2150) to electrode thread **6**.
4. Screw level transmitter into threaded standpipe or flange and tighten with an open-end spanner A. F. 41 mm. The torque required **when cold is 160 Nm**.

NRGT 26-1S

1. Check seating surfaces and place joint ring onto the connecting standpipe.
2. Put flange **8** with level transmitter onto connecting standpipe and bolt them together. Tighten bolts in diagonally opposite pairs.

Key

- 1** + **3** Max. length of installation at 238 °C
- 2** + **4** Measuring range
- 5** Joint ring 27 x 32, form D, DIN 7603, 1.4301, bright annealed
- 6** Thread G ¾ A to ISO 228 of transmitter
- 7** Thermal insulation, provided on site, d = 20 mm (outside of thermal insulation of steam boiler)
- 8** Flange DN 50, PN 40, DIN EN 1092-01
- 9** Protection tube
- 10** Spacer disc
- 11** Cable glands

Tools

- Open-end spanner A. F. 41, DIN 3110, ISO 3318

Examples of installation

NRGT 26-1

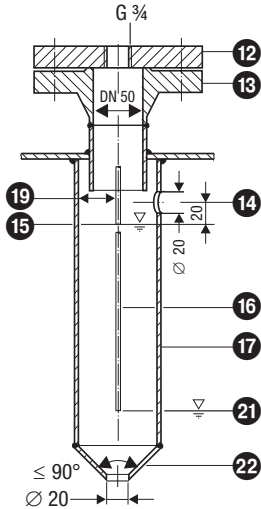

Fig. 5 Protection tube (provided on site) for installation inside the boiler

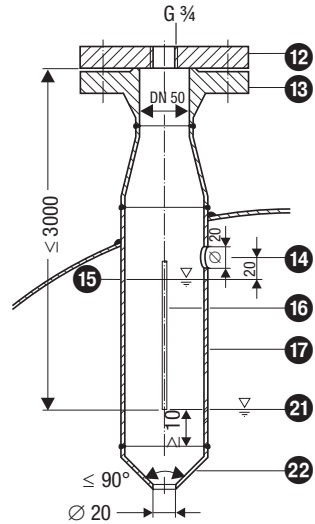

Fig. 6 Protection tube (provided on site) for installation inside the boiler

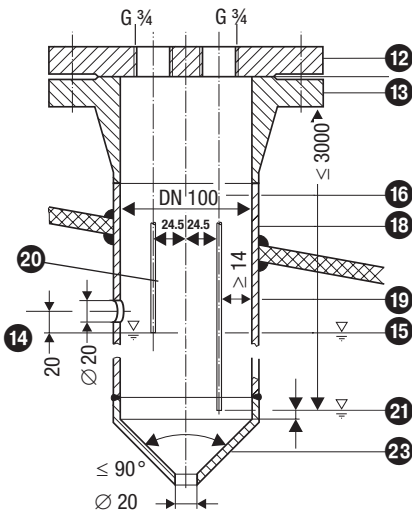

Fig. 7 Protection tube (provided on site) for installation inside the boiler and in combination with other GESTRA equipment

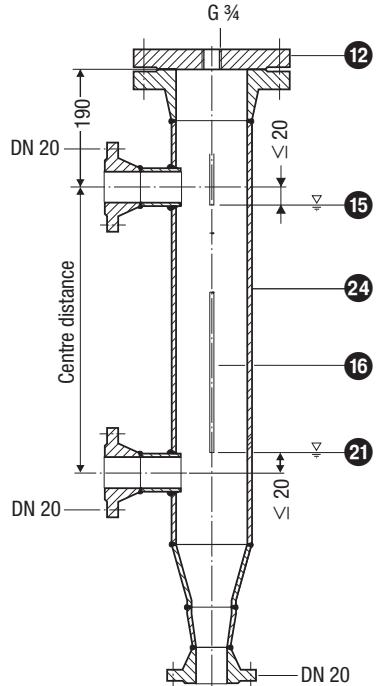

Fig. 8 External level pot

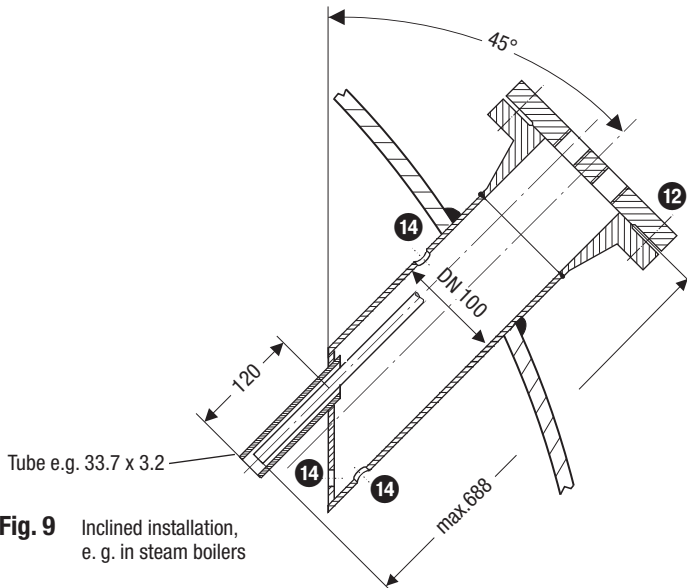

Fig. 9 Inclined installation,
e. g. in steam boilers

Key

- 12 Flange PN 40, DN 50, DIN EN 1092-01 (for one electrode)
Flange PN 40, DN 100, DIN EN 1092-01 (for electrode combination)
- 13 For the approval of the boiler standpipe with connecting flange the relevant regulations must be considered.
- 14 Vent hole \varnothing 20 mm
- 15 High water HW
- 16 Electrode rod
- 17 Protection tube DN 80 (in France according to AFAQ \geq DN 100)
- 18 Protection tube DN 100
- 19 Distance between electrode rod and protection tube \geq 14 mm
- 20 Distance between electrode tip (NRG 1...-50 or NRG 1...-51) \geq 14 mm (creepage distances and clearances)
- 21 Low water NW
- 22 Reducer DIN 2616-2, K-88.9x3.2-42.4 x 2.6 W
- 23 Reducer DIN 2616-2, K-114.3x3.6-48.3 x 2.9 W
- 24 Level pot \geq DN 80

Electrical connection

NRGT 26-1, NRGT 26-1S

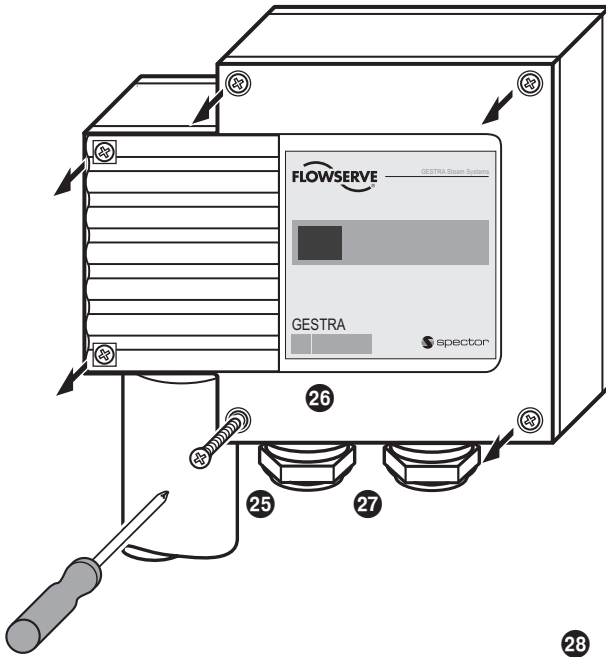

Fig. 10

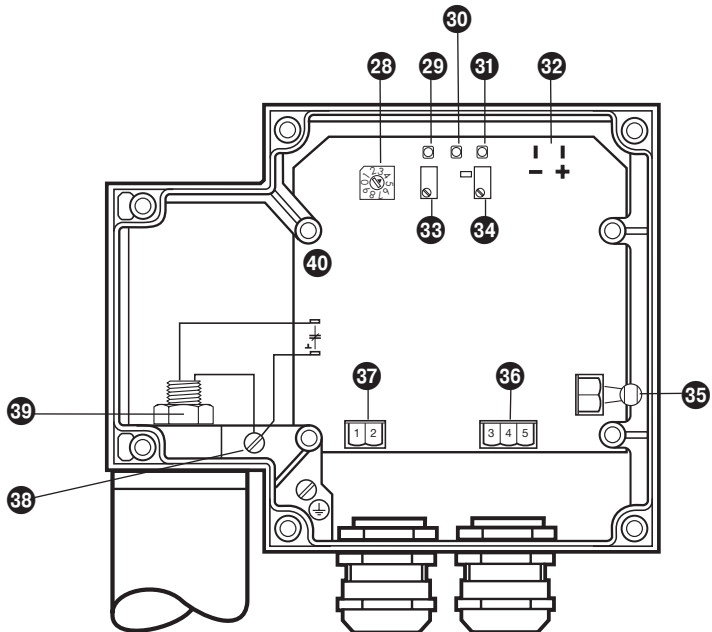

Fig. 11 Shown without cover plate

Electrical connection - continued -

Connection of level transmitter

A self-locking fixing nut **39** connects the terminal box to the electrode part. Before establishing the electrical connection you can turn the terminal box through max. +/- 180° into the desired direction (cable gland).

Connecting the NRGT 26-1, NRGT 26-1S

1. Unscrew housing screws **25** and remove housing cover **26**. **Fig. 10**
2. Remove terminal strips **36** and **37** from circuit board.
3. Strip off approx. 40 mm of cable insulation coating and remove approx. 5 mm of conductor end insulation.
4. Loosen cable glands **27**. If the equipment is supplied with 24 V pull control cable through one of the cable glands. Seal off the unused cable gland (protection IP 65). If the equipment is supplied with 115 / 230 V pull the power cable through the right cable gland and the control cable through the left.
5. Connect the individual cables according to the wiring diagram to terminal strip **36** and **37**.
6. Attach terminal strips **36** and **37** to the circuit board.
7. Tighten cable glands **27**.
7. Mount cover **26** and fasten cover screws **25**.



Attention

- The following relocations of cables with basic insulation are not permissible:
Mains and control cables in low voltage areas.

Key

- | | |
|---|---|
| 25 Cover screws (cross-recess head M4) | 33 Potentiometer for lower measuring point |
| 26 Cover | 34 Potentiometer for upper measuring point |
| 27 Cable glands M 20 x 1.5 | 35 Thermal fuse T _{MAX} 102 °C |
| 28 Selector switch for measuring range | 36 Terminal strip for supply voltage |
| 29 LED "Level 0 %" | 37 Terminal strip for actual-value output |
| 30 LED "Level > 0 %, < 100 %" | 38 Connection for functional earth |
| 31 LED "Level 100 %" | 39 Fixing nut for terminal box |
| 32 Terminal lugs for voltage measurement (between 0 - 7 V, level proportional) | 40 Fixing screw for electronic circuit board |

Tools

- Screwdriver, size 1
- Screwdriver, size 2.5, completely insulated according to DIN VDE 0680-01

Wiring diagram for level transmitter NRG26-1, NRG26-1S

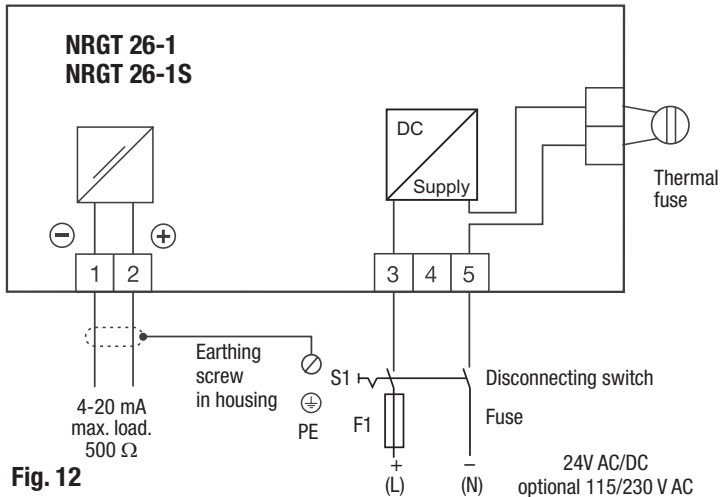

Fig. 12

Connecting level transmitter NRG26-.. with supply voltage 24 V AC/DC

An external slow-blow fuse 0.5 A must be provided for the level transmitter. For the connection use screened multi-core control cable with a min. conductor size 0.5 mm², e. g. LiYCY 4 x 0.5 mm², max. length 100 m.

For the power supply of the level transmitter use a safety power supply unit (PSU), e.g. Siemens SITOP PSU100C 24V/0.6A, which must provide a level of isolation against voltages that at least meets the requirements for double or reinforced insulation as per DIN EN 50178 or DIN EN 61010-1 or DIN EN 60730-1 or DIN EN 60950 (electrically protective separation).

Connecting level transmitter NRG26-.. with supply voltage 115 / 230 V AC

An external slow-blow fuse 0.5 A must be provided for the level transmitter. To connect the voltage supply use a multi-core control cable with a min. conductor size 0.5 mm². To connect the actual value output use screened multi-core control cable with a min. conductor size 0.5 mm², e. g. LiYCY 2 x 0.5 mm², max. length: 100 m.

Install a disconnecter for all poles. Make sure it is easily accessible and in the close proximity of the equipment (EN 61010-1). Mark this disconnecting switch as isolating device for the level transmitter.

Actual value output

Any item of equipment that you want to connect to the terminals for the actual-value output 4 - 20 mA must be certified to have at least double or reinforced isolation according to DIN EN 50178 or DIN EN 61010-1 or DIN EN 60730-1 or DIN EN 60950 (safe electrical isolation) between the current loop and live parts of the equipment that are not supplied with safety extra-low voltage (SELV).

Make sure that the connecting cable is segregated and runs separately from power cables. Please observe the max. load of 500 ohm.

Basic settings

Factory setting NRGT 26-1

The level transmitter features the following factory set default values:

- Measuring range 300 mm: Switch 28 position 4, water $\geq 20 \mu\text{S/cm}$
- Measuring range 400 mm to 700 mm: Switch 28 position 4, water $\geq 20 \mu\text{S/cm}$
- Measuring range 800 mm to 1500 mm: Switch 28 position 4, water $\geq 20 \mu\text{S/cm}$
- Measuring range 1600 mm to 2000 mm: Switch 28 position 5, water $\geq 20 \mu\text{S/cm}$

Factory setting NRGT 26-1S

The level transmitter features the following factory set default values:

- Measuring range 275 mm: Switch 28 position 4, water $\geq 20 \mu\text{S/cm}$
- Measuring range 375 mm to 675 mm: Switch 28 position 4, water $\geq 20 \mu\text{S/cm}$
- Measuring range 775 mm to 1475 mm: Switch 28 position 4, water $\geq 20 \mu\text{S/cm}$
- Measuring range 1575 mm to 1975 mm: Switch 28 position 5, water $\geq 20 \mu\text{S/cm}$

Establishing active measuring range (control range)

Within the measuring range of the transmitter you can establish the active control range.

Use switch 28 to establish the length of the active measuring range. Switch 28 see Fig. 11.

- ⊗ Selected (active) measuring range [mm]
- ② ④ Measuring range [mm] = xxx % see Fig. 2 and 3
- ④① Lower end of measuring range, adjustable
- ④② Upper end of measuring range, adjustable
- ⑤ Water, conductivity $\geq 20 \mu\text{S/cm}$
- ⑥ Water, conductivity $\geq 5 \mu\text{S/cm}$
- ⑦ Fuel oil EL, dielectric constant ϵ_r 2,3

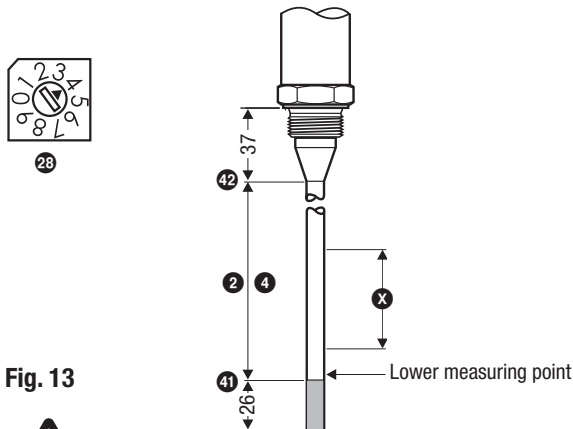

Fig. 13



Attention

- If ⊗ is clearly smaller than ② ④ set switch 28 one step back.

⊗	⑤	⑥	⑦
100	4	3	3
200	4	3	3
300	4	3	3
400	4	4	3
500	4	4	3
600	4	4	3
700	4	4	3
800	4	4	3
900	4	5	3
1000	4	5	3
1100	4	5	3
1200	4	5	3
1300	4	5	3
1400	4	5	3
1500	4	5	3
1600	5	5	3
1700	5	6	3
1800	5	6	4
1900	5	6	4
2000	5	6	4

Commissioning procedure



Danger

The terminal strip of the level transmitter is live during operation. This presents the danger of electric shock! Cut off power supply before mounting or removing the housing cover! Use only a completely insulated screwdriver according to VDE 0680 for setting the measuring points.

Applying supply voltage

Please check that the level transmitter is wired in accordance with the wiring diagram (**Fig. 12** page 16) and switch on mains voltage. When the electrode tip is exposed the LED is illuminated **29**. **Fig. 11**

Adjusting lower end of measuring range

1. Unscrew cover screws **25** and remove cover **26**. **Fig. 10**
2. Lower liquid level until the lower end of the measuring range is reached.
3. Raise the pressure in the steam boiler or vessel until the service pressure is reached.
4. Turn potentiometer **33** to the left until the red LED **29** lights up.
5. Turn potentiometer **33** to the right until **only** the green LED **30** lights up. The lower end of the measuring range is now adjusted.

Adjusting upper end of measuring range

1. Fill tank and wait for 30 seconds (internal attenuation).
2. Turn potentiometer **34** to the right until **only** the red LED **31** lights up.
3. Turn potentiometer **34** to the left until the green LED **30** lights up.
4. Turn potentiometer **34** to the right until the green LED **30** goes out. The upper end of the measuring range is now adjusted.
5. Mount cover **26** and fasten cover screws **25**.



Note

- When adjusting the measuring range when the system is **cold**, the adjusted measuring points will shift with rising temperature as a result of the longitudinal expansion of the electrode rod. Correct the settings accordingly.
- If a higher accuracy (for 0 % = 4 mA and 100 % = 20 mA) than ± 0.5 mA is required, measure the level-proportional current at terminals 1 \ominus and 2 \oplus in order to establish more accurate settings.

Troubleshooting

Indication, diagnosis and remedy



Attention

Before carrying out the fault diagnosis please check:

Supply voltage:

Is the level transmitter supplied with the mains voltage specified on the name plate?

Wiring:

Is the wiring in accordance with the wiring diagram?

Malfunctions	
Equipment does not work accurately	
Error	Remedy
The transmitter was installed without a protection tube. The protection tube is required because it serves as reference electrode.	Install a protection tube.
The vent hole in the protection tube does not exist, is obstructed or flooded.	Check protection tube and, if necessary, provide vent hole.
The isolating valves of the external level pot (optional) are closed.	Open isolating valve.
The desired lower measuring point is outside the measuring range of the transmitter. The transmitter is too short.	Install a sufficiently long level transmitter.
The adjustment of the measuring range is wrong.	Correct switch 23 settings. See Basic Settings
The electrode rod is covered with dirt deposits.	Remove level transmitter and clean the electrode tip with a wet cloth.
The transmitter is defective. Actual value output (terminals 1 and 2) > 20 mA. Fig. 12	Replace level transmitter.

Equipment fails to work	
Error	Remedy
Power failure.	Switch on supply voltage. Check all electrical connections.
Thermal fuse 35 defective.	Discard and replace defective thermal fuse. Stock code # 052433. Check ambient temperature, make sure that it does not exceed 70° C.
The earth connection to the vessel is interrupted.	Clean seating surfaces and screw in the level transmitter together with the joint ring 27 x 32, form D, DIN 7603 (made from 1.4301), bright annealed. Do not insulate the level transmitter with hemp or PTFE tape!
Electronic circuit board defective	Exchange the electronic insert.

Replacing electronic module

1. Unscrew cover screws 25 and remove housing cover 26.
2. Pull electrode wires from terminal lugs on module. Detach terminal strips 36 37.
3. Undo the functional earth 38 connection.
4. Unscrew the fixing screws 40 for the electronic module and take out the module.
The module is available as spare part.

Stock code #	NRGT 26-1	NRGT 26-1S
321317	230 V AC	
321340	115 V AC	
321354	24 V AC/DC	
321319		230 V AC
321342		115 V AC
321355		24 V AC/DC

5. Install the new electronic module in reverse order.



Note

After replacing the electronic module please re-commission the equipment.

Maintenance

Safety note

The equipment must only be installed, wired and commissioned by qualified and competent staff. Retrofitting and maintenance work must only be performed by qualified staff who - through adequate training - have achieved a recognised level of competence.



Danger

When loosening the level transmitter steam or hot water might escape!
This presents the risk of severe scalding all over the body!
It is therefore essential not to dismantle the level transmitter unless the boiler pressure is verified to be 0 bar.

The level transmitter becomes hot during operation.
Risk of severe burns to hands and arms.

Before carrying out installation and maintenance work make sure that the equipment is cold.

Cleaning the electrode rod

The equipment may only be installed and removed by qualified personnel. Observe note in chapter "Installation" on page 11.

Before cleaning the electrode rod decommission and remove the level transmitter.

Clean the electrode rod with a wet cloth.

Removing and disposing of the level transmitter

Removing and disposing of level transmitter NRG T 26-1, NRG T 26-1S

1. Switch off supply voltage.
2. Unscrew cover screws 25 and remove housing cover 26.
3. Disconnect the connecting wires from the terminal strips 36 37 and pull wires out of the cable gland.
4. Before removing the equipment make sure that it is neither hot nor under pressure.

For the disposal of the level transmitter observe the pertinent legal regulations concerning waste disposal.

If faults occur that are not listed above or cannot be corrected, please contact our service centre or authorized agency in your country.



GESTRA

Agencies all over the world:

www.gestra.com

Great Britain

Flowserve GB Limited

Abex Road
Newbury, Berkshire RG14 5EY
Tel. 0044 16 35 / 46 99 90
Fax 0044 16 35 / 3 60 34
E-Mail gestraukinfo@flowserve.com
Web www.flowserve.com

Singapore

Flowserve Pte. Ltd.

12 Tuas Avenue 20
Singapore 63882
Tel. 0065 / 68 79 89 00
Fax 0065 / 68 62 49 40
E-Mail fcd_gestra_singapore@flowserve.com
Web www.gestra.com

South Africa

Flowserve SA (Pty) Ltd.

Unit No. 1
Director Road
Spartan Extension 2
Kempton Park 1613
Tel. 0027 11 / 9 23 73 00
Fax 0027 11 / 9 74 64 20
E-Mail tvniekerk@flowserve.com
Web www.flowserve.com

USA

Flowserve GESTRA U.S.

2341 Ampere Drive
Louisville, KY 40299
Tel. 001 502 / 267-22 05
Fax 001 502 / 266-53 97
E-Mail fcd-gestra-usa@flowserve.com

GESTRA AG

P. O. Box 10 54 60, D-28054 Bremen
Münchener Str. 77, D-28215 Bremen
Tel. 0049 (0) 421 / 35 03-0
Fax 0049 (0) 421 / 35 03-393
E-mail gestra.ag@flowserve.com
Web www.gestra.com

