

NRG 16-36 with four-pole connector

Level Electrode NRG 16-36

Description

The level electrode NRG 16-36 is used in conjunction with level switch NRS 1-50 as water level limiter for steam boilers and (pressurised) hot-water installations and in conjunction with level switches NRS 1-52 / NRS 1-54 or NRS 1-2 / NRS 1-5 as water level controller.

Water level limiters switch off the heating when the water level falls below the set minimum level (low water).

Function

The NRG 16-36 is a combination level electrode consisting of 1 electrode tip for low level alarm (LW) and 3 electrode tips for water level control with high level alarm (MAX).

The electrode operation is based on the conductive measuring principle using the electrical conductivity of the water for signalling water level. The high integrity self-monitoring function in the level limiter ensures that an alarm will also be triggered if the electrode insulation is contaminated or has developed a leak and/or if there is a malfunction in the electrical connection.

The length of the individual electrode rods determines the switchpoints for the respective water levels.

The level electrode is installed inside steam boilers, vessels or in an external level pot. If the electrode is installed inside the boiler or vessel, a protection tube provided on side ensures correct functioning.

If the level electrode is installed in an isolatable level pot outside the boiler, make sure that the connecting lines are rinsed regularly. In addition, the logic unit SRL is required to monitor the purging times and the purging sequence.

If the connecting lines for steam ≥ 40 mm and water ≥ 100 mm, the installation is considered to be internal. In this case the rinsing processes do not have to be monitored.

Technical Data

Operating pressure

PN 40, 32 bar at 238 °C

Mechanical connection

Screwed BSP 1 ½ A, ISO 228

Materials

Screw-in body 1.4571, X6CrNiMoTi17-12-2

Electrode tips 1.4571, X6CrNiMoTi17-12-2

Electrode insulation Gylon®, PTFE

Spacer disks PTFE

Terminal box 3.2161 G AISi8Cu3

Lengths available

400 mm, 1000 mm, 1500 mm

Electrical connection

Terminal box made from aluminium, with 2 four pole connector with screw terminals, 2 cable glands Pg 11

Protection

IP 65 to EN 60529

Ambient temperature

Max. 70 °C

Weight

Approx. 4.5 kg (L=1000 mm)

Approvals

TÜV type approvals acc. to

VdTÜV Bulletin "Wasserstand 100": Requirements made on water level limiting & control equipment.

Type approval no. TÜV · WR / WB · 09-370; 10-424;

SWB · 09-422 (see name plate)

Gylon® is a registered trademark of Garlock Sealing Technologies, Palmyra NY, USA

Directives and standards

EC Pressure Equipment Directive 97/23/EC

Water level limiters are safety accessories as defined in the Pressure Equipment Directive (PED). The level electrode NRG 16-36 in conjunction with level switch NRS 1-50 is EC type approved according to EN 12952/EN 12953. These Directives state, among other things, the requirements made on limiting systems and equipment for steam boiler plants and (pressurised) hot-water installations.

Functional Safety acc. to IEC 61508

The level electrodes NRG 1...-50 / NRG 16-36 are certified acc. to IEC 61508 only if used in combination with level switch NRS 1-50. This standard describes the functional safety of safety-related electrical/electronic/programmable electronic systems.

The equipment combination NRG 1...-50 or NRG 16-36 + NRS 1-50 corresponds to a type B subsystem with Safety Integrity Level (SIL) 3.

VdTÜV Bulletin "Wasserstand 100" (= Water Level 100)

The level electrodes NRG 1-50, NRG 1...-11 and NRG 16-36 in conjunction with the level switch NRS 1-50 are type approved according to the VdTÜV Bulletin "Water Level 100".

The level electrode NRG 16-36 is also type approved in conjunction with with level switches NRS 1-52 / NRS 1-55 or NRS 1-2 / NRS 1-5.

The VdTÜV Bulletin "Wasserstand (=Water Level) 100" specifies the requirements made on water level control and limiting equipment for boilers.

ATEX (Atmosphère Explosible)

The level electrodes NRG 1...-50, NRG 1...-11 and NRG 16-36 are simple items of electrical equipment as specified in EN 60079-11 section 5.7. According to the European Directive 94/9/EC the equipment must be equipped with approved Zener barriers if used in potentially explosive areas. Applicable in Ex zones 1, 2 (1999/92/EC). The equipment does not bear an Ex marking.

The suitability of the Zener barriers is certified in a separate document. Note that the requirements of the IEC 61508 are not met if the NRG 1...-50, NRG 1...-11, NRG 16-36 + Zener barriers + NRS 1-50 are interconnected!

Level Electrode NRG 16-36

Important Notes

Installation

If installed outdoors the level electrode must be equipped with a GESTRA weather protection cover.
The level electrode shall be installed vertically.

Electrical connection

To connect the level electrode use two multi-core overall screened control cables in separated conduits.

To connect the level tip for low water level (LW) alarm please use:

■ For the level switch NRS 1-50 with a response sensitivity of 10 μ S: Multi-core screened control cable, min. conductor size 0.5 mm², e. g. LiYCY 4 x 0.5 mm², max. length 100 m.

■ For the level switch NRS 1-50 with a response sensitivity of 0.5 μ S: Multi-core double-screened low-capacitance data cable, min. conductor size 0.5 mm², Li2YCY PiMF 2 x 2 x 0.5 mm², max. length 30 m.

To connect the electrode tips 6, 7 and 8 use multi-core screened control cable, min. conductor size 0.5 mm², e. g. LiYCY 5 x 0.5 mm², max. length 100 m.

Connect the screen only once to the central earthing point (CEP) in the control cabinet.

Order & Enquiry Specification

GESTRA Level electrode type NRG 16-36
PN ..., connection G 1 1/2, Inspection
Length suppliedmm

Key

- 1 Thermal insulation, provided on site, d = 20 mm (outside of thermal insulation of steam boiler)
- 2 Terminal box
- 3 Electrode thread BSP 1 1/2 A, ISO 228
- 4 Electrode tips 6, 7 and 8
- 5 Electrode tip for low water (LW)
- 6 Spacer disc
- 7 Measuring surface extension for electrode tips 6, 7, 8
- 8 Measuring surface extension for low water (LW)
- 9 Flange PN 40, DN 50, DIN EN 1092-01
- 10 For the approval of the boiler standpipe with connecting flange the relevant regulations must be considered.
- 11 Vent hole
- 12 Distance between electrode tips and protection tube ≥ 14 mm
- 13 Protection tube DN 100
- 14 Low water (LW)
- 15 Reducer DIN 2616-2, K-114.3 x 3.6-48.3 x 2.9 W
- 16 Flange PN 40, DN 100, DIN EN 1092-01
- 17 High water (HW)
- 18 Level pot \geq DN 80

Supply in accordance with our general terms of business.

Dimensions NRG 16-36

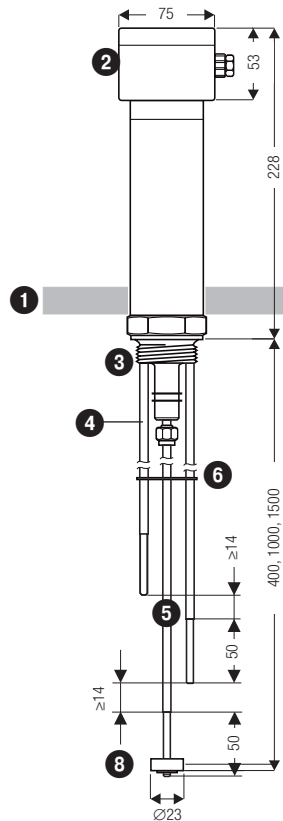

Fig. 1 NRG 16-36 (dimensions are applicable for conductivity < 10 μ S/cm / measuring length > 1000 mm)

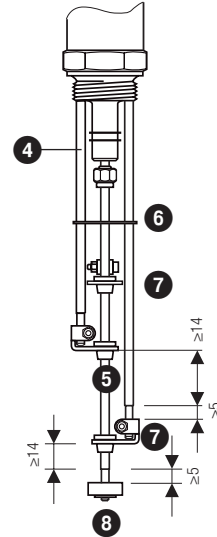

Fig. 2 NRG 16-36 (dimensions are applicable for conductivity < 10 μ S/cm / measuring length > 1000 mm)

Examples of installation

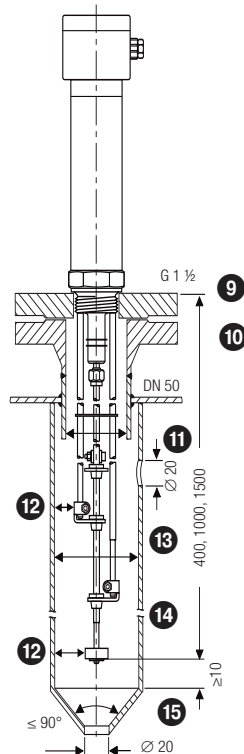

Fig. 3 Protection tube (provided on site) if electrode is used as internal water-level limiter

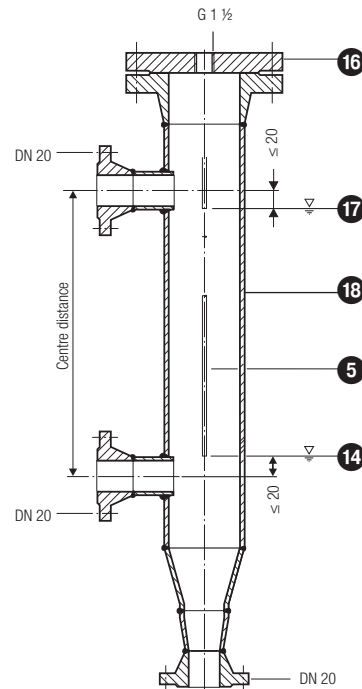

Fig. 4 Level pot if electrode is used as external water level limiter

GESTRA AG

P. O. Box 10 54 60, D-28054 Bremen
Münchener Str. 77, D-28215 Bremen
Tel. 0049 (0) 421 35 03-0, Fax 0049 (0) 421 35 03-393
E-mail gestra.ag@flowserve.com, Web www.gestra.com

